

PC23 | PC43

Desktop Printer

PC23d, PC43d, PC43t



User Manual

Intermec by Honeywell

6001 36th Ave.W.
Everett, WA 98203
U.S.A.

www.intermec.com

The information contained herein is provided solely for the purpose of allowing customers to operate and service Intermec-manufactured equipment and is not to be released, reproduced, or used for any other purpose without written permission of Intermec by Honeywell.

Information and specifications contained in this document are subject to change without prior notice and do not represent a commitment on the part of Intermec by Honeywell.

© 2012–2014 Intermec by Honeywell. All rights reserved.

The word Intermec, the Intermec logo, Fingerprint, Ready-to-Work, and SmartSystems are either trademarks or registered trademarks of Intermec by Honeywell.

For patent information, please refer to www.hsmpats.com

Wi-Fi is a registered certification mark of the Wi-Fi Alliance.

Microsoft, Windows, and the Windows logo are registered trademarks of Microsoft Corporation in the United States and/or other countries.

Bluetooth is a trademark of Bluetooth SIG, Inc., U.S.A.



The products described herein comply with the requirements of the ENERGY STAR. As an ENERGY STAR partner, Intermec Technologies has determined that this product meets the ENERGY STAR guidelines for energy efficiency. For more information on the ENERGY STAR program, see www.energystar.gov. The ENERGY STAR does not represent EPA endorsement of any product or service.

Document Change Record

This page records changes to this document. The document was originally released as Revision 001.

Version Number	Date	Description of Change
005	12/2014	Revised to support MR7 firmware release.
004	2/2014	Added updated information on installing InterDriver.
003	8/2013	Added information to support the latest firmware version K10.05: <ul style="list-style-type: none">• How to select a printer command language on the icon printer.• How to print a test label in idle mode.• Updated media specifications.• Descriptions of the printer command languages.• How to print on RFID media.
002	8/2012	Added or revised content: <ul style="list-style-type: none">• New procedure for printing test labels from the icon printer.• New illustrations of the label dispenser accessory.• ENERGY STAR logo and description.• Information on using tag media and linerless media.• Information on the optional thick media springs.

Contents

Before You Begin.....	xi
Safety Information.....	xi
Safety Precautions.....	xi
Global Services and Support.....	xii
Warranty Information.....	xii
Web Support.....	xiii
Send Feedback.....	xiii
Telephone Support.....	xiii
Who Should Read This Manual.....	xiii
Related Documents.....	xiv

1 About the Printers..... 1

About the PC23 and PC43.....	2
Printer Features.....	3
About the Front Panel.....	6
About the Ready-to-Work Indicator.....	6
About the Icon Front Panel.....	7
About the LCD Front Panel.....	8
About the Ready Screen.....	9
View Basic Printer and Connection Information.....	11
About the Main Menu.....	12
Navigate in the Main Menu.....	13
About the Onscreen Keypads.....	14
About the Printer Wizards.....	15
Use a Wizard.....	17
About Printer Command Languages.....	17
About Fingerprint.....	18
About Direct Protocol.....	18
About IPL.....	18
About ESim.....	18
About ZSim.....	19
About DSim.....	19
About Smart Printing.....	19
About ESim/ZSim Auto-Configuration.....	19
How to Set the Printer Command Language.....	20
Set the Command Language from the Printer Web Page.....	20
Set the Command Language from the Main Menu.....	21
Set the Command Language with the Print Button.....	21

Contents

Mount the Printer on a Wall	22
PC23 Wall-Mounting Template	24
PC43 Wall-Mounting Template	25
Printer Options and Accessories	26
About the Battery Base	27
Battery Base LEDs	29
Battery Precautions	30
Charge the Battery	31
Power the PC43d with the Battery Base	31

2 Set Up the Printer **33**

About Media	34
About Linerless Media.	34
About Tag Media	34
Adjust the Media Holders.	34
About Tear-Off Printing	37
Load Media for Tear-Off Printing	37
About Cut-Off Printing	42
Load Media for Cut-Off Printing	43
About the Label Dispenser	47
Load Media for the Label Dispenser	48
Load External Media	53
Load Ribbon.	54
Use the Notchless Ribbon Core Adapter.	58
Connect the Printer to Power	60
Use the Setup Wizard.	61
How to Set Up an Icon Printer	62
Set Up an Icon Printer without a Network Option	62
Set Up an Icon Printer with Ethernet	63
Set Up an Icon Printer with Wi-Fi	63
Calibrate the Media Feed and Print Test Labels on the Icon Printer.	64
Set the Command Language with the Print Button	64
About Test Labels	65
Print a Test Label in Start Up Mode.	65
Print a Test Label in Idle Mode	65
Print a Test Label from the Main Menu	66

How to Print on RFID Media 66
 About RFID Tag Position 67
 Run the RFID Calibration Wizard 68
 Calculate RFID Tag Position 69

3 Connect the Printer 71

About Printer Drivers 72
 Install Printer Drivers 72
 How to Connect the Printer to Your PC 73
 Connect the Printer Using a USB Cable 74
 Connect the Printer Using a Serial or Parallel Cable 75
 How to Connect the Printer to Your Network 76
 Connect the Printer to an Ethernet Network 76
 About Wi-Fi Communications 77
 Connect the Printer to a Wireless Network 77
 Configure Wi-Fi Communications from the Printer Web Page 80
 About Bluetooth Communications 81
 Connect to a Bluetooth Device by Reading a Bar Code 82
 Connect to a Bluetooth Device Using a Wizard 82
 Configure Bluetooth Communications from the Main Menu 83
 Configure the Printer from the Web Page 83
 About the USB Host Port 85
 Connect a USB Device 85

4 Configure the Printer 87

About Printer Configuration Settings 88
 How to Configure the Printer 89
 View the Configuration Summary 89
 Configure the Printer from the Web Page 90
 Configure the Printer from the Main Menu 92
 Configure the Printer with PrintSet 5 92
 How to Configure the Printer with Programming Commands 93
 How to Configure the Printer with SmartSystems 93

Contents

About Printer Profiles	93
Save a Printer Profile from the Main Menu	94
Load a Printer Profile from the Main Menu	94
How to Load a Printer Profile with Programming Commands	95
About USB Storage Device Directories	95
Print a File from a USB Storage Device	96
Upload Applications and Files from a USB Storage Device	96
Export Applications and Files to a USB Storage Device	97
Export a Configuration File to a USB Storage Device	97
Install a Configuration File from a USB Storage Device	98
Upload or Delete Applications and Resources from the Printer Web Page	99

5 Troubleshoot the Printer101

Call Product Support	102
Locate the Printer Configuration and Serial Numbers	103
About Printer System Information	103
View Printer Statistics	104
Check the Printer Odometer	105
About Alerts	106
Configure Alerts	107
Maintenance and Error Alert Messages	108
Problems and Possible Solutions	110
Restore Defaults by Using a Hardware-Based Reset	114
Restore Defaults from the Printer Web Page	115
Restore Defaults from the Main Menu	117
How to Upgrade the Printer Firmware	118
Download the Printer Firmware Update	118
Upgrade Firmware from the Printer Web Page	118
Upgrade Firmware from a USB Storage Device	119
Upgrade Firmware from the USB Menu	120

6 Maintain the Printer 121

Clean the Printhead 122

Replace the Printhead 123

Clean the Platen Roller 125

Clean the Exterior of the Printer 127

Recommended Cleaners 127

A Specifications 129

Printer Specifications 130

Supported Bar Code Symbologies 135

Test Labels 138

Print Quality Labels 142

B Default Settings 145

Default Configuration 146

 Bluetooth Settings 146

 Display and Audio Settings 147

 Error, Information, and Warning Alert Settings 148

 Error Alerts 150

 Information Alerts 150

 Warning Alerts 150

 Ethernet Settings 151

 General System Settings 152

 Media Settings 153

 Print Quality Settings 157

 Serial Port Settings 158

 System I/O Settings 159

 System Network Services 160

 System Maintenance Alert Settings 161

 Wireless 802.11 General Settings 162

 Wireless 802.11 Network Settings 163

 Wireless 802.11 Security Settings 164

C Print Labels with INPrint 167

 About the INPrint Page.....168

 Print INPrint Labels.....168

 Predefined INPrint Label Formats.....170

Before You Begin

This section provides you with safety information, technical support information, and sources for additional product information.

Safety Information

Your safety is extremely important. Read and follow all warnings and cautions in this document before handling and operating Intermec equipment. You can be seriously injured, and equipment and data can be damaged if you do not follow the safety warnings and cautions.

This section explains how to identify and understand warnings, cautions, and notes that are in this document.



Warning: A warning alerts you of an operating procedure, practice, condition, or statement that must be strictly observed to avoid death or serious injury to the persons working on the equipment.



Caution: A caution alerts you to an operating procedure, practice, condition, or statement that must be strictly observed to prevent equipment damage or destruction, or corruption or loss of data.



Note: Notes either provide extra information about a topic or contain special instructions for handling a particular condition or set of circumstances.

Safety Precautions

- Read and review this manual carefully before connecting the printer.
- Because moving parts are exposed when the cover is open, ensure that the cover is closed before you operate the printer.
- Do not put your fingers inside the print mechanism when the power is on.
- Place the printer on an even surface which can safely support its weight and supplies.

Before You Begin

- Do not spray the printer with water. If you are using a hose to clean the premises in an industrial environment, remove the printer or carefully protect it from spray and moisture.
- You must implement both hardware and software safety precautions to prevent the possibility of undefined system states.
- You must ensure that dangerous conditions cannot occur under any circumstances, even for a brief period of time.
- Observe all safety and accident prevention regulations applicable to your specific region and application.
- Before you use a cleaning card, carefully read the warning text on the envelope.
- Replace only with same type and rating of fuse to ensure continued protection against risk of fire.
- If you are using the printer with the Battery Base:
 - Risk of explosion if battery is replaced by an incorrect type.
 - Use of another battery may present a risk of fire or explosion.
 - The battery may present a fire or chemical burn hazard if mistreated. Do not disassemble the battery, heat above 100 °C (212 °F), or incinerate.
 - Dispose of any used batteries according to the instructions.



Note: This equipment may be used on an IT power system.

Global Services and Support

Warranty Information

To understand the warranty for your Intermec product, visit the Intermec web site at www.intermec.com and click **Support** > **Returns and Repairs** > **Warranty**.

Disclaimer of warranties: The sample code included in this document is presented for reference only. The code does not necessarily represent complete, tested programs. The code is provided “as is with all faults.” All warranties are expressly disclaimed, including the implied warranties of merchantability and fitness for a particular purpose.

Web Support

Visit the Intermec website at www.intermec.com to download our current manuals (in PDF).

Visit the Intermec technical knowledge base (Knowledge Central) at www.intermec.com and click **Support > Knowledge Central** to review technical information or to request technical support for your Intermec product.

Send Feedback

Your feedback is crucial to the continual improvement of our documentation. To provide feedback about this manual, please contact the Technical Communications department directly at ACSHSMTechnicalCommunications@honeywell.com.

Telephone Support

In the U.S.A. and Canada, call **1-800-755-5505**.

Outside the U.S.A. and Canada, contact your local Intermec representative. To search for your local representative, from the Intermec web site, click **About Us > Contact Us**.

Who Should Read This Manual

This user manual is for the person who is responsible for installing, configuring, operating, and maintaining the PC23 and PC43 printers.

This document provides you with information about the features of the printer, and how to install, configure, operate, maintain, and troubleshoot it.

Before you work with the printer, you should be familiar with your printer command language and general printing setup. If you are going to use the printer in a network, you should be familiar with your network and general networking terms, such as IP address.

Related Documents

The Intermec website at www.intermec.com contains our documents (as .pdf files) that you can download for free.

To download documents

- 1 Visit the Intermec website at www.intermec.com.
- 2 Click the **Products** tab.
- 3 Using the **Products** menu, navigate to your product page. For example, to find the PC43 product page, click **Printers** > **Desktop** > **PC43**.
- 4 Click the **Manuals** tab.

If your product does not have its own product page, click **Support** > **Manuals**. Use the **Product Category**, the **Product Family**, and **Product** to find your documentation.

1

About the Printers

This chapter introduces the PC23 and PC43 printers, and includes descriptions of printer features and basic operation.

About the PC23 and PC43

The PC23 and PC43 printers are compact, easy-to-use bar code label printers that fit easily on a desktop. The printers can be connected to a single desktop PC for stand-alone operation or to a wired or wireless network for ease of connectivity.

Both printers are available in direct thermal (DT) models. The PC43 is also available in a thermal transfer (TTR) model for printing with a ribbon.

Features of both printers include:

- Print speeds of up to 8 ips (203 dpi printhead) or 6 ips (300 dpi printhead)
- Multiple, selectable printer languages including Intermec Fingerprint, Direct Protocol, Intermec Printer Language (IPL), ESim, and ZSim
- Optional Wi-Fi/Bluetooth dual radio module
- Optional Ethernet module
- USB ports for storage devices, keyboards, or scanners, and for connections to a PC (including serial or parallel connections with appropriate adapters)
- (PC43d only) Optional battery and battery base
- (PC43t only) Support for 12 mm (0.5 in) or 25 mm (1.0 in) ribbon core sizes
- LCD or Icon interface available
- Available RFID module (factory-installed only: HF for PC23, UHF for PC43)
- Complete range of accessories
- CCXv4 certified



Note: The PC23 and PC43 printers with an IEEE 802.11b/g/n radio installed are Wi-Fi® certified for interoperability with other 802.11b/g/n wireless LAN devices.

Printer Features

Use the next illustrations to locate printer features.

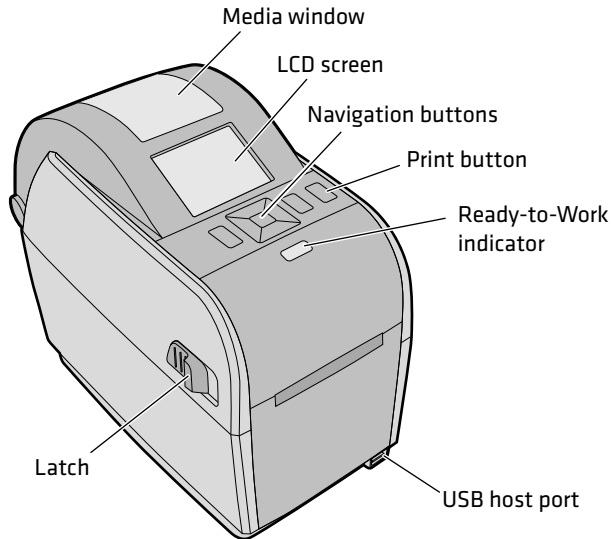

PC23d Front Panel (LCD Model)

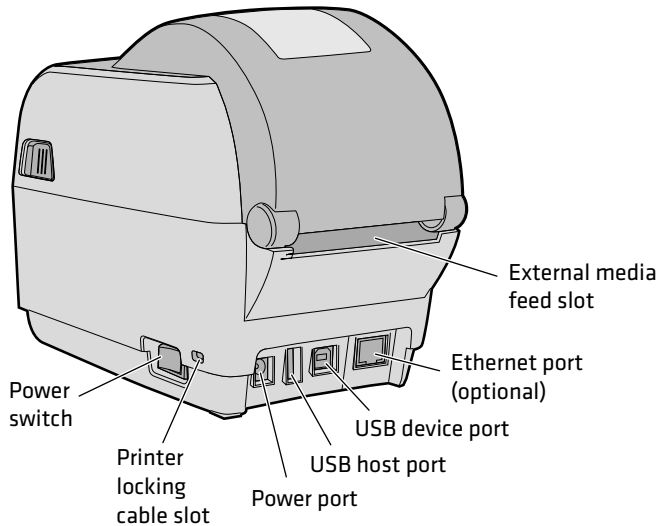

PC23d Rear Panel

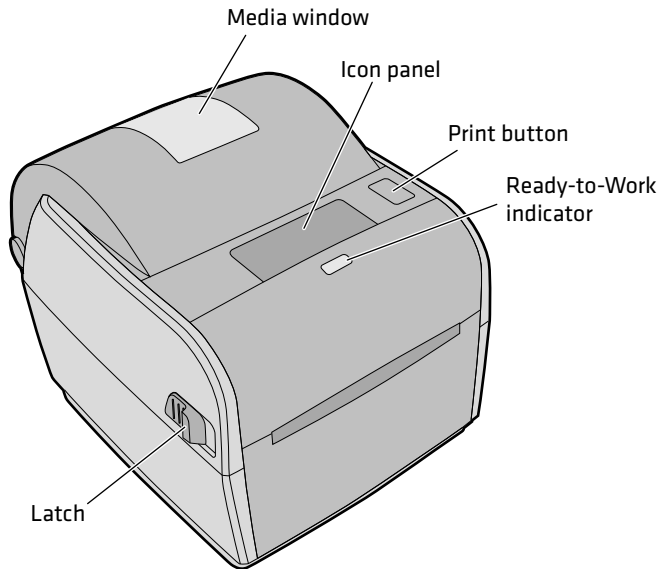

PC43d Front Panel (Icon Model)

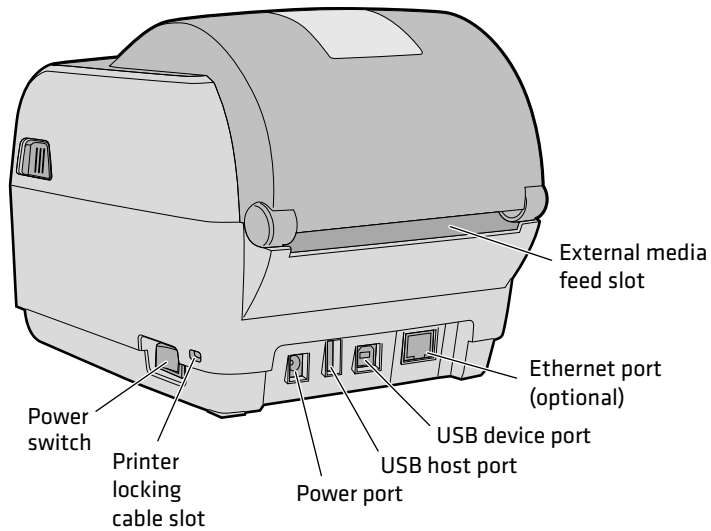

PC43d Rear Panel

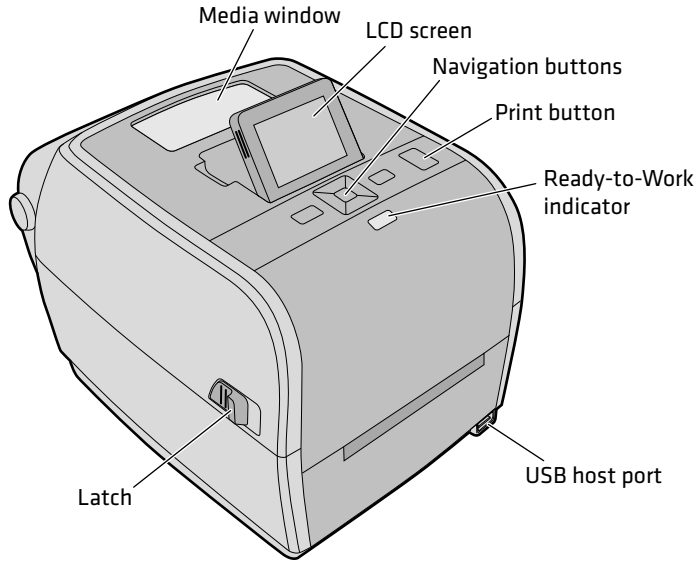

PC43t Front Panel (LCD Model)

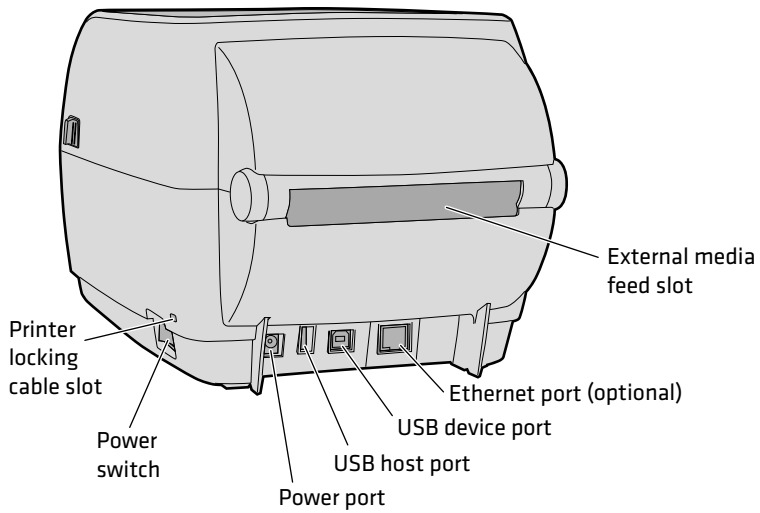

PC43t Rear Panel

About the Front Panel

There are two front panels available for the printers:

- LCD (liquid crystal display)
- Icon (no display)

Both versions of the front panel include the Print button and the Ready-to-Work™ indicator. The PC23 and PC43 with the LCD also have a USB host port on the front panel.

About the Ready-to-Work Indicator

The Ready-to-Work indicator on the front of the printer turns on when the printer is ready to print.

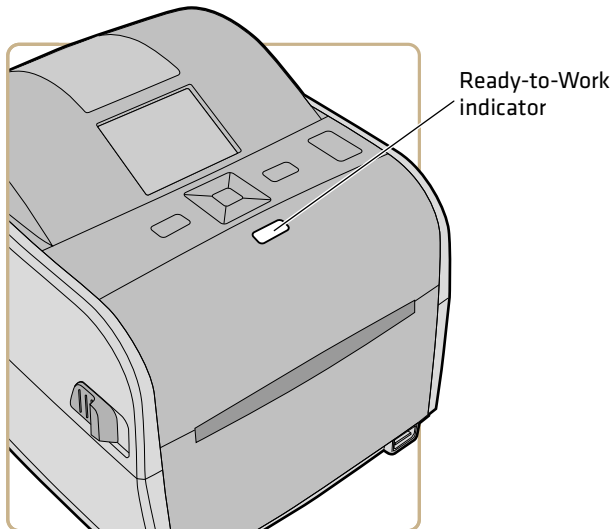

Ready-to-Work Indicator Location

Ready-to-Work Indicator Status

Ready-to-Work Indicator Status	Description
On	Printer is ready for a print job.
Blinking	Printer is not ready for a print job.

Ready-to-Work Indicator Status (Continued)

Ready-to-Work Indicator Status	Description
Off	Printer is turned off, not communicating, or not ready to print. For example, the printer may still be starting up, or a firmware upgrade is underway.



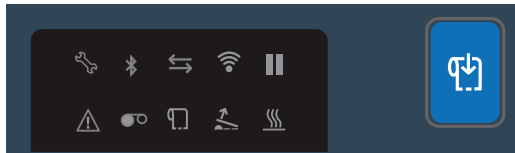

About the Icon Front Panel

The icon front panel includes a graphical panel and a Print button.







As you use the printer, the icons turn on or off to indicate printer status.

Icon Front Panel - Status Icons

Icon	Color and Description	Printer Models
	Steady: Maintenance needed; odometer setting reached; Firmware upgrade in progress Flashing: Firmware is currently resetting all defaults, or printer in calibration mode	All
	On: Bluetooth is enabled Off: Bluetooth is not enabled, or Wi-Fi/Bluetooth module is not installed	With Wi-Fi/Bluetooth module
	Flashing: Sending or receiving data Steady: No data in motion through the network connection Off: No connection	All
	On: Wi-Fi is enabled Off: Wi-Fi is not enabled, or Wi-Fi/Bluetooth module is not installed	With Wi-Fi/Bluetooth module
	On: Printer is paused Off: Printer is not paused	All

Icon Front Panel - Status Icons (Continued)

Icon	Color and Description	Printer Models
	On: General error Off: No errors	All
	On: Ribbon is jammed or empty Off: No error	TTR only
	On: Media is jammed or empty Off: No error	All
	On: Print mechanism is open or not latched properly Off: Print mechanism is closed correctly	All
	On: Printhead too hot Off: Printhead temperature OK	All

About the LCD Front Panel

The printer LCD interface includes a screen, navigation buttons, and a Print button.

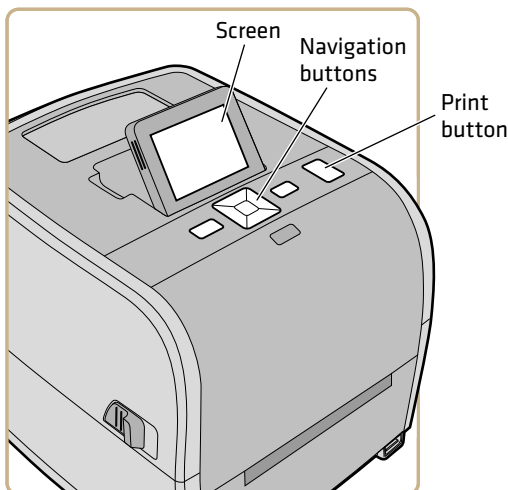

PC43t Printer with LCD Interface





On the PC43t, you can adjust the screen for the best viewing angle.

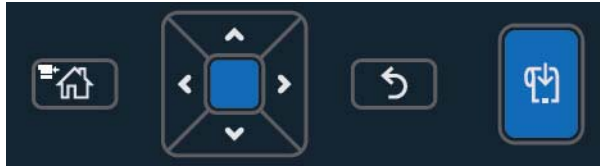

Caution: Do not tilt the screen past its maximum angle or you could damage the screen.



LCD Interface Navigation Button Descriptions

Button	Description
	Menu/Home button. Press to toggle between the Ready screen and the printer Main Menu.
	Directional pad: Press ^ , v , < , or > to move the selection highlight to another item. Press ■ to select the highlighted item and to save settings in a menu or list.
	Back button. Press to return to the previous menu or page, or to break from a running Fingerprint application.
	Print button. Press to begin printing, or to feed a single label.

About the Ready Screen

After you turn the printer on, the Ready screen appears when the printer finishes starting up.

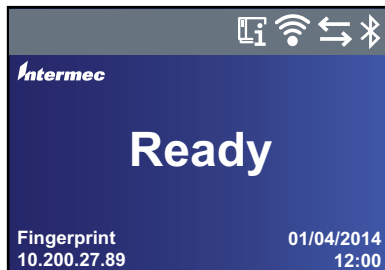

Ready Screen













Note: Icons for Wi-Fi and Bluetooth status appear only when the optional Wi-Fi/Bluetooth module is installed. The IP address appears when the printer is connected to an Ethernet or wireless network and the Idle Information parameter is set to IPv4 address.

By default, the bottom of the screen shows the printer command language, the IP address, and the time and date. You can customize the screen as necessary to show different kinds of information.

The status bar at the top of the screen includes these information and status icons:

Information and Status Icon Descriptions

Icon	Description
	Printer Information icon. Select this icon to view basic printer information.
	Wi-Fi Connection icon. This icon appears when the Wi-Fi/Bluetooth module is installed in the printer and shows the strength of the Wi-Fi connection: <ul style="list-style-type: none"> - Strong. - Good. - Weak. - No signal. - Wi-Fi is disabled.
	Connectivity icon. Blinks when data is moving through a wired or wireless connection to the printer.
	Bluetooth icon. This icon appears when the Wi-Fi/Bluetooth module is installed: <ul style="list-style-type: none"> - Bluetooth is enabled. - Bluetooth is disabled.

View Basic Printer and Connection Information

In the Ready screen, use the control panel buttons to select an icon in the status bar at the top of the screen to view printer or connection information.

- 1 Press any arrow key to select the one of the icons in the status bar at the top of the Ready screen.

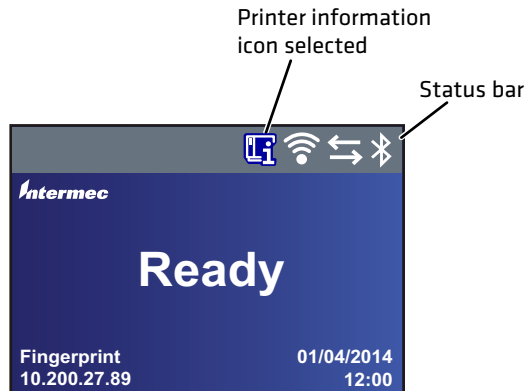

- 2 Press . A list of basic printer or connection information appears.

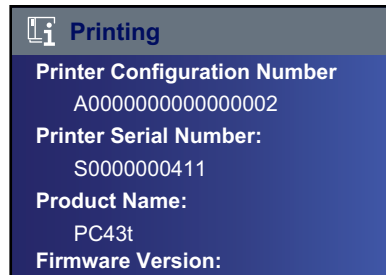

- 3 Press or to scroll through the list.
(Optional) Press or to view information for one of the other icons.
- 4 Press or to return to the Ready screen.

About the Main Menu

In the printer Ready screen, press  to view the Main Menu.

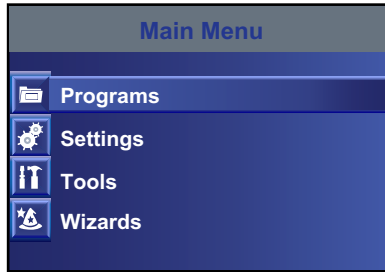

Press  and  to highlight Main Menu items, and then press  to select that item:

- Select **Programs** to see a list of programs installed on the printer. This list includes utility programs provided as part of the printer firmware, and programs you have installed on the printer. The **Programs** item appears in the Main Menu only if the printer is using Fingerprint or Direct Protocol as the command language.
- Select **Settings** to view and change printer settings.
- Select **Tools** to print test labels, manage a connected USB storage device, restore printer default settings, or save and load printer profiles.
- Select **Wizards** to see a list of wizards that help you configure printing or communication settings, or calibrate the media sensors.





Note: The printer cannot print while the Main Menu is on the screen. You need to exit the Main Menu and return to the Ready screen to begin printing.





Navigate in the Main Menu



Use the navigation buttons to select menus and menu items.





In the Main Menu:

- Press  to toggle between the Main Menu and the Ready screen.
- Press  to return to the Ready screen.

In the Programs, Settings, Tools, or Wizards menus:

- Press  and  to change the item in the list, and then press  (the center of the directional pad) to select the item. Another menu or a list of items appears.
- Press  to return to the previous screen or menu.
- Press  to return to the Ready screen.

In any list of items, press  or  to select another item in the list, and then press .

- If the item you selected requires you to select an option from a preset list, press  or  to scroll through the list items.
- If the item you selected requires alphabetic or numeric input, such as Network Name, press  and use the alphanumeric or numeric keypad on the screen to type a value.
- If you changed the value for an item, press  to save your changes. A “Saving...” message briefly appears to confirm that your changes have been saved.
- Press  to return to the previous screen. If you made changes without saving them, you are prompted to save your changes:
 - Select **Yes** to save your changes and return to the previous screen.
 - Select **No** to abandon your changes and return to the previous screen.
 - Select **Cancel** to abandon your changes and remain on the current screen.

About the Onscreen Keypads

When you are changing settings, you may need to use the alphanumeric or numeric keypads on the screen.

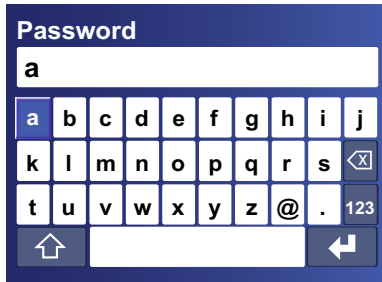

Alphanumeric Keypad - Alphabetic Characters

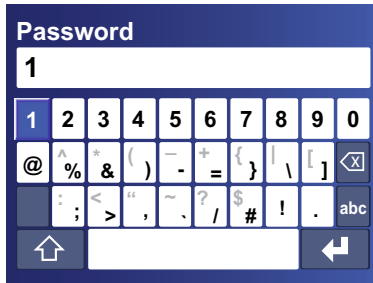

Alphanumeric Keypad - Numeric Characters and Punctuation

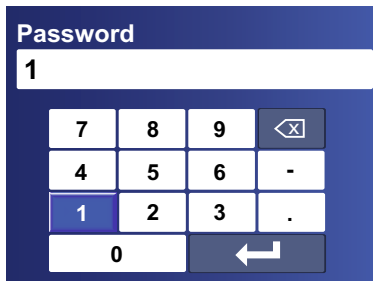

Numeric Keypad

For either keypad:

- Press **^**, **∨**, **◀**, or **▶** to select a character, and then press **■** to enter that character.
- Press **ⓧ** to delete the last character you entered.

For the alphanumeric keypad only:

- Select **123** or **ABC** and then press **■** to toggle between the alphabetic and numeric keys.
- In the alphabetic keypad, select **Ⓢ** and then press **■** to toggle between uppercase and lowercase letters.
- In the numeric keypad, select **Ⓢ** and then press **■** to toggle between shifted and unshifted key characters. For example, do this to toggle between \$ and # in the numeric keypad.

When you are finished typing characters, press **Ⓢ** to return to the list of items.

About the Printer Wizards

The printer firmware includes several wizards you can use to quickly set up printing and communications. You can start the wizards from the Main Menu.



Printing Wizards

Name	Description
Media Setup	Select media and printing type (DT or TTR), media width, length, and X-margin, Start and Stop Adjust values, and print speed.
Print Quality	Prints a series of labels to test print quality.
Loading Media	Shows how to load media.

Printing Wizards (Continued)

Name	Description
Loading Ribbon	(TTR printers only) Shows how to load a roll of ribbon.

Communications Wizards









Name	Description
Line Analyzer	Logs all incoming data on all communications channels and saves the data to a log file. For experienced users.
Wireless 802.11	Looks for wireless networks and sets up Wi-Fi communications. This item appears in the Communications wizards list when the optional Wi-Fi/Bluetooth module is installed.
Bluetooth	Looks for discoverable Bluetooth devices and sets up Bluetooth communications. This item appears in the Communications wizards list when the optional Wi-Fi/Bluetooth module is installed.

Calibration Wizard

Name	Description
Media	Calibrates the label stop sensor and shows current print settings.
RFID	Calibrates the RF power setting for the RFID module and adjusts RFID tag media settings for best performance. This item appears in the Calibration wizards list when the optional RFID module is installed in the printer.
Label Taken Sensor	Calibrates the label taken sensor. This item appears in the Calibration wizards list when the label dispenser or cutter accessory is installed.

Use a Wizard

The available wizards depend on the hardware you have installed in the printer.

- 1 From the Ready screen, press . The Main Menu appears.
- 2 Select **Wizards** and press .
- 3 Select a category and press .
- 4 Select a wizard from the list and press . The wizard begins.
- 5 In a wizard:
 - Use  or  to select items in a list.
 - Press  to select the highlighted item.
 - Select  and press  to continue to the next screen.

About Printer Command Languages

A printer command language is a set of instructions that controls printer functions:

- Configure the printer.
- Return the status of the printer.
- Control peripheral devices.
- Format a label or receipt for printing.

The printer supports these command languages and language simulator support options:

- Fingerprint
- Direct Protocol (DP)
- IPL (Intermec Printer Language)
- ESim (EPL command language simulator)
- ZSim (ZPL command language simulator)
- DSim (DPL command language simulator)
- Smart Printing

About Fingerprint

Fingerprint is a BASIC-inspired general purpose printer language. Use Fingerprint to design custom label formats and write printer application software. If you plan to run Smart Printing applications directly on the printer, without connecting to a PC, select Fingerprint as your printer command language. For more information, see the [Intermec Fingerprint Command Reference Manual](#).

The printer uses the Fingerprint printer command language by default.

About Direct Protocol

Direct Protocol (DP) is a subset of Fingerprint that uses a more intuitive English-like syntax. This flexible host-based printer command language can also be used with Smart Printing applications. Direct Protocol lets you combine predefined layouts and variable data to create labels, tickets, and tags. If you are using bar code software, like BarTender, select Direct Protocol as your printer command language.

About IPL

IPL (Intermec Printer Language) is a host-based printer command language. Use IPL to design, modify, and download label formats; write printer application software; and configure the printer. If you are sending IPL label files to the printer, select IPL as your printer command language. For more information, see the [IPL Command Reference Manual](#).

About ESim

ESim (EPL command language simulator) interprets Eltron® programs without requiring any host programming changes. If you are sending EPL label files to the printer, select ESim as your printer command language. For more information, see the [ESim Command Reference Manual](#).

About ZSim

ZSim (ZPL command language simulator) interprets Zebra™ programs (ZPL II or later) without requiring any host programming changes. If you are sending ZPL label files to the printer, select ZSim as your printer command language. For more information, see the [ZSim Command Reference Manual](#).

About DSim

DSim (DPL command language simulator) interprets Datamax™ data streams without requiring any host programming changes. If you are sending DPL label files to the printer, select DSim as your printer command language. For more information, see the [DSim Command Reference Manual](#).

About Smart Printing

Smart Printing refers to the ability of the printer to independently run printing operations without being connected to a host computer. If you are running printer-based applications written in C#, select Smart Printing as your printer command language.

For help creating Smart Print applications, go to the Intermec Developer Center at www.intermec.com/developer.

About ESim/ZSim Auto-Configuration

Use the ESim/ZSim auto-configuration feature when you are replacing another printer whose command language is unknown.

When the printer command language is set to ESim/ZSim, on its first run the printer automatically calibrates the media, identifies the command language of the first incoming print job, configures the printer for the appropriate language (ESim or ZSim), and prints the label.



Note: Load media before you turn the printer on, since the printer automatically calibrates the media when it starts in ESim/ZSim auto-configuration mode.

The data stream must be at least 10 bytes long. Command language identification is activated after a 2-second timeout, or when the data buffer is full (1 MB).

The printer command language is saved to memory, and remains set to ESim/ZSim until you change this setting.

How to Set the Printer Command Language

You can use one of these methods to change the printer command language:

- Printer web page
- Main Menu
- PrintSet 5. For more information, see the PrintSet 5 online help.

Set the Command Language from the Printer Web Page

To set the command language from the printer web page, you need to turn on the printer and connect to your Ethernet or Wi-Fi network.









Note: If you are using an icon printer without an Ethernet or Wi-Fi network, you must use the Print button or PrintSet 5 to set the printer command language.

- 1** Make sure that the printer has media and ribbon (if necessary) installed.
- 2** On your PC, open a browser.
- 3** In the **Location** or **Address** bar, type the printer IP address and press **Enter**. The printer web page appears.
- 4** Click **Login**. The Login page appears.
- 5** Type your **Username** and **Password** and click **Login**. The default username is `itadmin` and the default password is `pass`.
- 6** Click the **Configure** tab.
- 7** Click **System Settings > General**.
- 8** Select a different printer command language from the **Command Language** list, and then click **Save**.
- 9** Click the **Services** tab.
- 10** Click **Reboot Printer**, and then click **Reboot**. The printer restarts in the command language you selected.

Set the Command Language from the Main Menu



If you have an LCD printer, you can change the printer command language from the Main Menu.

- 1 Make sure that the printer has media and ribbon (if necessary) installed.
- 2 From the Ready screen, press . The Main Menu appears.
- 3 In the Main Menu, select **Settings > System Settings > General**.
- 4 In the **General** settings list, press  to scroll to **Command Language**.
- 5 Press  or  to select a different command language.
- 6 Press  or .
- 7 Press  to save your changes.

If you are prompted to enter a password for DSIm or ZSim, the password is 1138. To return to the Fingerprint menu system from DSIm or ZSim, the password is 8311.

Set the Command Language with the Print Button

If you have an icon printer, you can use the **Print** button to set the printer command language.

- 1 Make sure that the printer has media and ribbon (if necessary) installed.
- 2 Turn off the printer.
- 3 Turn the printer back on. All the LEDs light up. As the printer starts up, the LEDs turn off one by one, starting with the bottom right LED.
- 4 When the last two LEDs (Maintenance and Bluetooth) are lit, press and hold . The printer feeds a few labels as it automatically adjusts the media feed, and then the test labels start to print.
- 5 Continue to hold . The available printer command languages start to print.

- 6 When you see the language you want to use, release .
- 7 The printer automatically reboots and starts in the command language you selected.

Mount the Printer on a Wall

You can mount the printers vertically on a wall or other surface. The printer must be mounted so the media output slot faces down. Use the following guidelines for selecting a mounting location:

- Choose a location within 1.5 m (5 ft) of an electrical outlet.
- Choose appropriate mounting hardware (not supplied) for the mounting surface.
- The mounting hardware must provide at least 6 mm (0.25 in) of clearance between the mounting surface and the bottom of the screw head. The screw head width should be 6 to 8 mm (0.24 to 0.33 in).
- Intermec recommends that you use pan-head or flathead screws with appropriate anchors for drywall, or for cement, concrete block, or plasterboard walls. Use wood screws only for wooden surfaces, and ensure the screw is long enough to be sunk to a depth of at least 12.5 mm (0.5 in).



Caution: Be sure that the mounting surface can safely support the weight of the printer.

- 1 Choose the appropriate wall-mount template for your printer and use the template to locate and drill holes in the mounting surface.



Note: For mounting to wood surfaces, use a drill of 5 to 8 mm (0.2 to 0.3 in), or as appropriate for your mounting hardware.

- 2 Install the mounting hardware. If you need to use anchors, install them first.

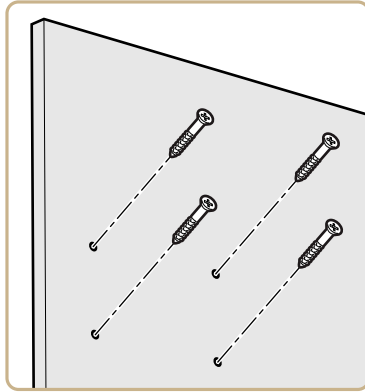

- 3 Place the printer mounting holes on the mounting hardware and slide the printer down to lock it in place.

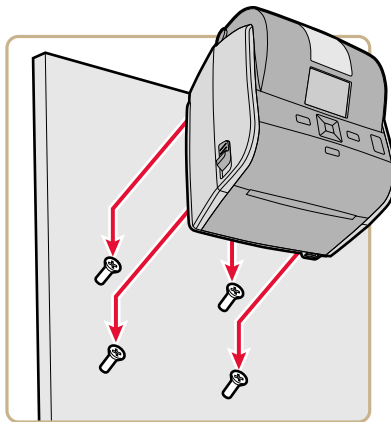

PC23 Wall-Mounting Template

Use this template to correctly locate wall-mounting hardware for the PC23d printer.

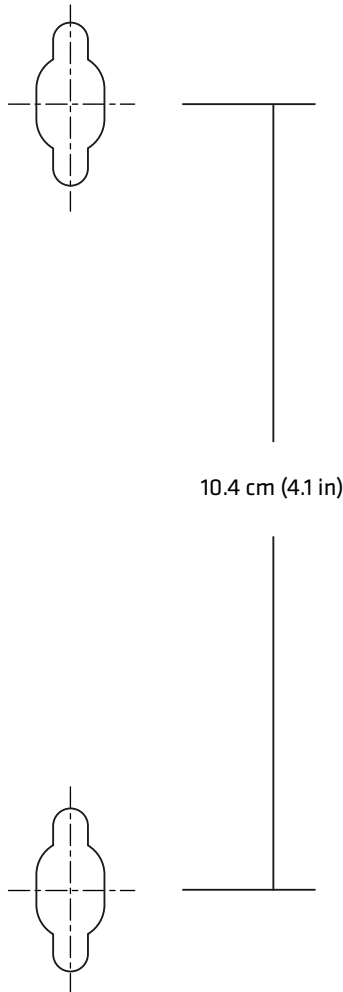

PC23 Wall-Mounting Template

PC43 Wall-Mounting Template

Use this template to correctly locate wall-mounting hardware for the PC43d and PC43t printers.

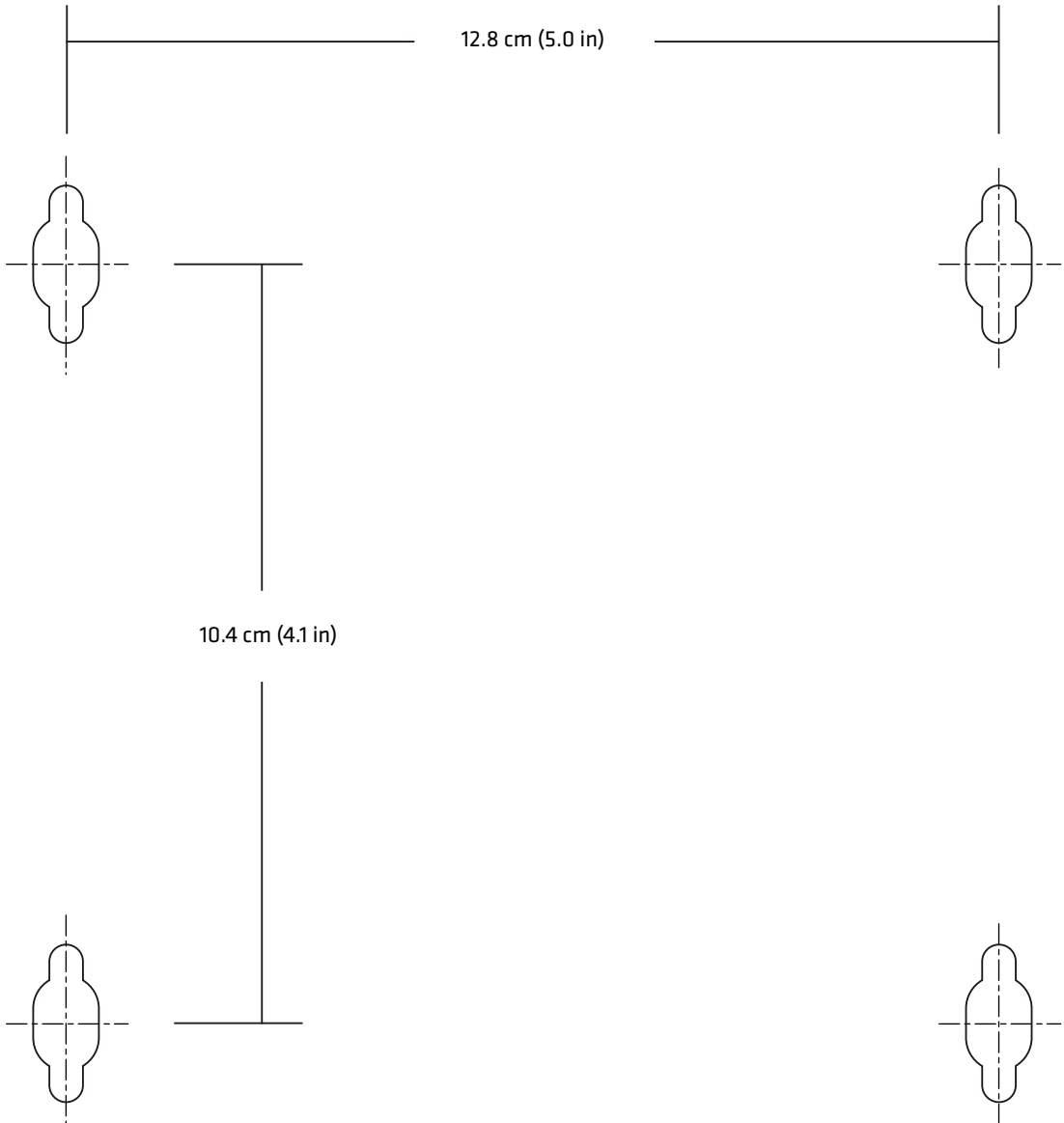

PC43 Wall-Mounting Template

Printer Options and Accessories



Note: Some printer configurations do not support all accessories. For more information, contact your local Intermec representative.

Printer Options and Accessories

Accessory	Description
300-dpi Printhead	Replaces the standard 203-dpi printhead.
USB-to-Serial Adapter	USB to RS-232 adapter. Connects to printer USB Host port and provides serial connectivity to a PC.
USB-to-Parallel Adapter	USB to IEEE 1284 adapter. Connects to printer USB Host port and provides DB25 connectivity to a PC or other equipment.
Ethernet Module	RJ-45 adapter installs on back panel of printer and provides IEEE 802.3 Ethernet connection. Supports 10BaseT and 100BaseTx. Ethernet and Wi-Fi/Bluetooth modules can be installed at same time.
Wi-Fi/Bluetooth Module	Radio module can be installed in all printers and provides Wi-Fi and Bluetooth connectivity. Wi-Fi/Bluetooth and Ethernet modules can be installed at same time. <ul style="list-style-type: none">• Wi-Fi supports static and dynamic WEP, WPA, WPA2, EAP-PEAP, EAP-TTLS, LEAP, EAP-FAST, and EAP-TLS security protocols• Bluetooth v2.1+EDR supported
Label Dispenser Module	Removes paper backing and presents labels one at a time for pickup. Includes Label Taken Sensor.
Cutter Module	Provides automatic cutting as labels are printed. Includes Label Taken Sensor. For PC43.
Cutter Tray	Holds up to 20 labels as they are cut. Installs on Cutter Module. For PC43.

Printer Options and Accessories (Continued)

Accessory	Description
Media Cover Lock Bracket	With customer-supplied lock, allows media cover to be secured.
Linerless Roller	Non-stick platen roller dispenses printed labels when you use linerless media stock. For PC43.
Battery Base	Pedestal-style base holds rechargeable battery (sold separately) and attaches to base of printer. Uses printer AC power adapter to charge battery. For PC43d.
Rechargeable battery	For use with Battery Base.
Power Adapter Base	Pedestal-style base attaches to base of printer and holds AC power adapter. For PC43d.
Thick Media Springs	Heavier-gauge springs increase printhead pressure for best results when printing on tag media.

These replacement parts are also available for the PC23 and PC43:

- 203-dpi printhead
- Standard platen roller
- AC power adapter

For information on these accessories and replacement parts, contact your Intermec representative.

About the Battery Base

Instead of using the AC power supply, you can use the optional battery base to provide power for the PC43d printer. Depending on your printer duty cycle, the rechargeable battery in the battery base provides up to 8 hours of power.



Note: Battery life depends on many factors. The battery is designed to provide 8 hours of charge (plus one hour of standby time) when you are printing a 150-mm (6-in) label every 7 minutes.

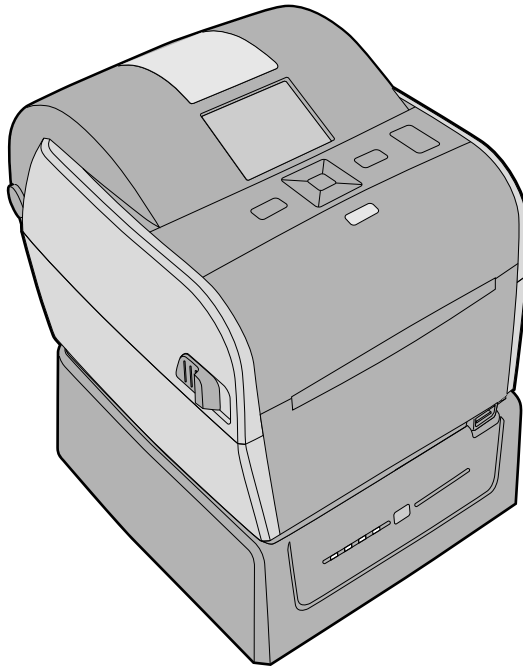

PC43d Printer and Battery Base

For help installing the printer on the battery base, see the [PC43d Battery Base Installation Instructions](#).









Note: Printing speed depends on the actual battery charge level. The maximum print speed for a PC43d running on battery power is 6 ips for 203 dpi and 4 ips for 300 dpi.

Battery Base LEDs

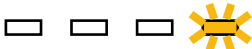

When the battery base is connected to AC power, the LEDs indicate the battery charge status.

LEDs: Battery Base Connected to AC Power

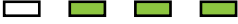
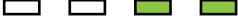

LEDs	Battery Charge Status
	95% to 100%
	76% to 94%
	51% to 75%
	26% to 50%
	0% to 25%
	Battery out of charging temperature range.
	Battery error.

When the battery base is not connected to AC power, you can press the **Charge Level** button to briefly turn on the LEDs and see the battery charge level.

LEDs: Battery Base Not Connected to AC Power

LEDs	Battery Charge Level
	Battery is 76% to 100% charged.
	Battery is 51% to 75% charged.
	Battery is 26% to 50% charged.
	Battery is 11% to 25% charged.

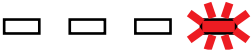
LEDs: Battery Base Not Connected to AC Power (Continued)

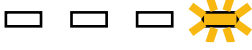
LEDs	Battery Charge Level
	Battery is 0% to 10% charged.
	Battery out of operating temperature range.
	Battery error.

Battery Precautions

Follow these precautions when using the printer with the Battery Base:

- Use only the battery supplied by Intermec. Risk of explosion if battery is replaced by an incorrect type. Use of another battery may present a risk of fire or explosion.
- The battery may present a fire or chemical burn hazard if mistreated.
- Do not disassemble the battery, heat above 100 °C (212 °F), or incinerate.
- Dispose of any used batteries according to the instructions that came with the battery.

Charge the Battery

When the battery base is connected to AC power, the LEDs indicate the charging status of the battery.

- 1 Make sure that the PC43d is properly installed on the base. For help, see the [PC43d Battery Base Installation Instructions](#).
- 2 Connect the power cord from the battery base to the printer.
- 3 Connect the battery base to AC power.

The battery begins to charge and the battery base LEDs turn on to indicate charge status. The battery is fully charged in 4 hours.

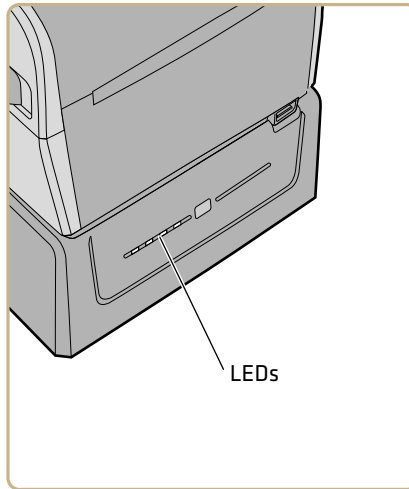

Power the PC43d with the Battery Base

After you charge the battery, you can use the battery base accessory to power the PC43d printer. When the battery base is not connected to AC power, press the **Charge Level** button on the front of the base to turn on the LEDs and see the current charge level.

- 1 Charge the battery in the battery base.
- 2 Disconnect the power cable from AC power.
- 3 Turn on the printer. The LEDs on the battery base turn off.

- 4 To see the current battery charge level, press the **Charge Level** button on the front of the base.

The battery base LEDs briefly turn on to indicate the current charge level. The LEDs turn off to save power.

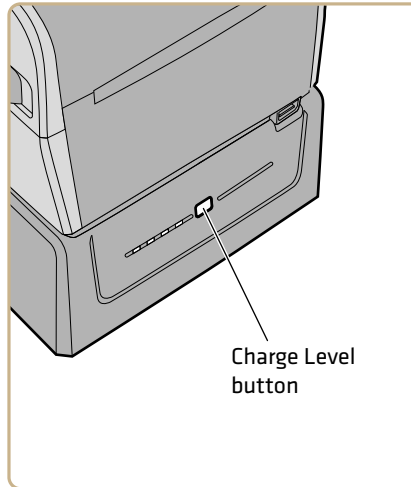

2

Set Up the Printer

This chapter explains how to load media and ribbon, print test labels, and adjust the print quality.

About Media

The printers can print on labels, tickets, tags, and continuous stock. The procedure you use to load media depends on how you are operating the printer and the options you have installed.

About Linerless Media

If you are printing on linerless media, follow these guidelines for best results:

- You must install the linerless roller accessory before printing. For more information on this accessory, contact your local sales representative.
- When removing printed labels on linerless media, tear the label up towards the top of the printer to prevent media jams.
- Do not use linerless media with the cutter accessory.

About Tag Media

If you are printing on tag media, follow these guidelines for best results:

- Install the optional thick media springs before printing. For more information on this accessory, contact your local sales representative.
- After you install the thick media springs, adjust the Media Sensitivity and Darkness settings for best print quality.
- To extend the life of the printhead, Intermec recommends that you install the original springs when printing on other types of media.

Adjust the Media Holders

The first time you load media in the printer, or when you use different sizes of media, you must adjust the media holders. After you adjust the media holders, you do not need to adjust them again for a new roll of the same size media.



Note: The illustrations show the PC43d printer. Adjusting the media holders is done the same way for all printers.

- 1** Pull one or both of the printer latches toward the front of the printer and lift the printer lid.

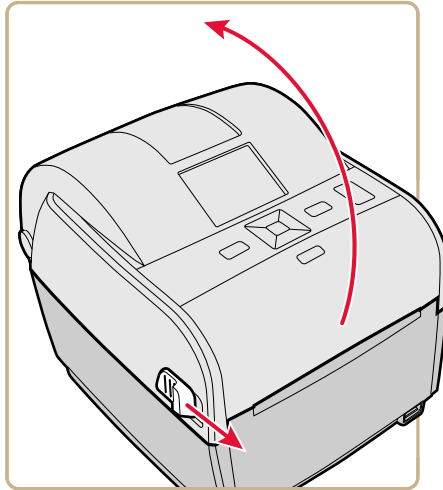

- 2** Pull the locking tab up.

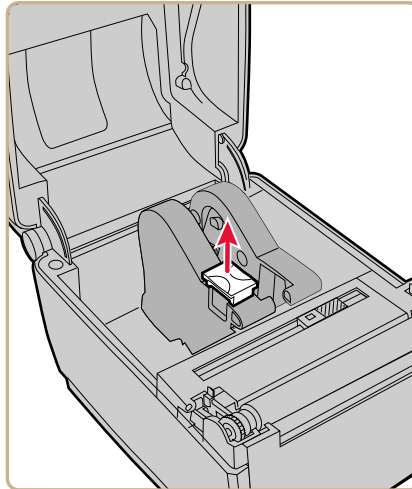

- 3** Slide the media holders to adjust the distance between them, and place the media roll between the holders.

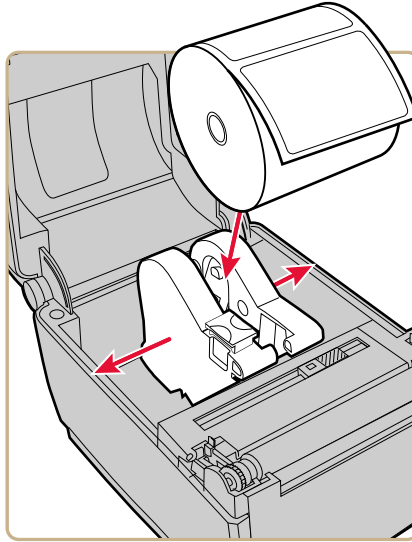

- 4** Make sure the holders are snug against the sides of the media roll, and then press the locking tab down to lock the media holders in place.

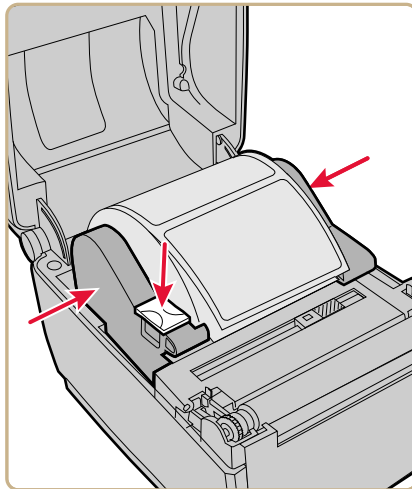

About Tear-Off Printing

In tear-off printing, you manually tear printed labels, tickets, wristbands, and other printed media from the front of the printer.

After you load media, you need to configure the feed adjust settings. These settings allow for printing from the top edge of the label. You may need to adjust the recommended values slightly depending on your media type, supply method, and roll sizes, or because of individual differences between printers.



Note: Feed adjust values for simulator command languages like ESim, ZSim, and DSim are preset.

Recommended Feed Adjust Values for Tear-Off Printing

Printer	Setting	203 dpi	300 dpi	Distance
PC23d	Start Adjust	-113	-168	-14.24 mm (-0.56 in)
	Stop Adjust	0	0	0 mm (0 in)
PC43d	Start Adjust	-124	-183	-15.50 mm (-0.61 in)
	Stop Adjust	0	0	0 mm (0 in)
PC43t	Start Adjust	-108	-160	-13.60 mm (-0.54 in)
	Stop Adjust	0	0	0 mm (0 in)

Load Media for Tear-Off Printing

Depending on the type of media you use, you may also need to install a printer accessory. If you need to print on tag media, Intermec recommends installing the optional thick media springs before printing. If you need to print on linerless media, you must install the linerless media roller accessory before printing.



Note: When removing printed labels on linerless media, tear the label up towards the top of the printer to prevent media jams.

Chapter 2 – Set Up the Printer

- 1 Pull one or both of the printer latches toward the front of the printer and lift the printer lid.

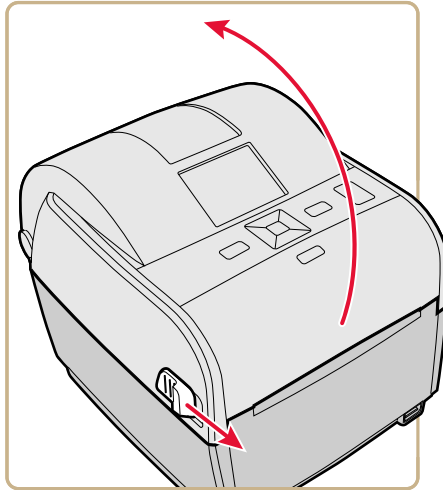

- 2 If there is an empty media core in the media compartment, remove the core.
- 3 If you are going to load the same size media, continue with the next step.

If you are using large rolls of media stored outside the printer, such as in an external media holder, feed the media through the external media feed slot.

To adjust the media holders for a different media size:

- a** Pull the locking tab up.

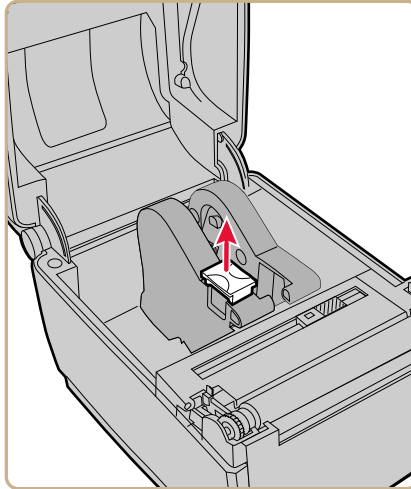

- b** Slide the media holders to adjust the distance between them, and place the media roll between the holders.

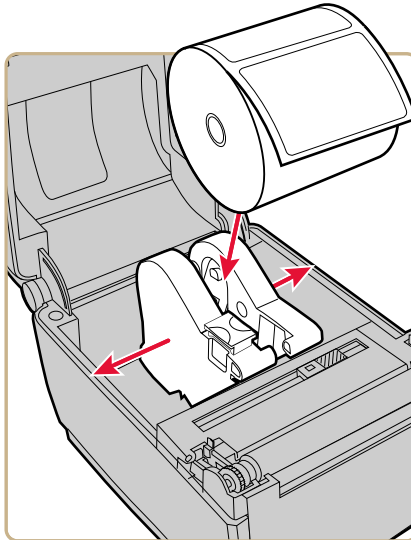

- c Make sure the media holders are snug against the sides of the media roll, and press the tab down to lock the media holders in place.

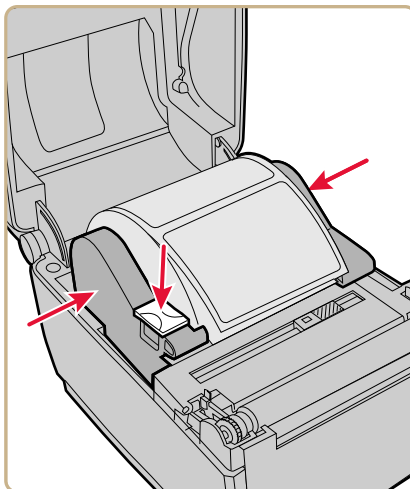

- 4 If you are using notched or black mark stock, slide the label stop sensor so the notches or marks pass over the sensor.

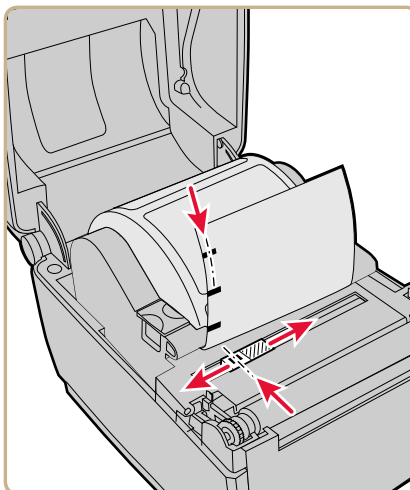

- 5** For the PC23d and PC43d, thread the media under the tip guides on the media holders and past the front of the printer.

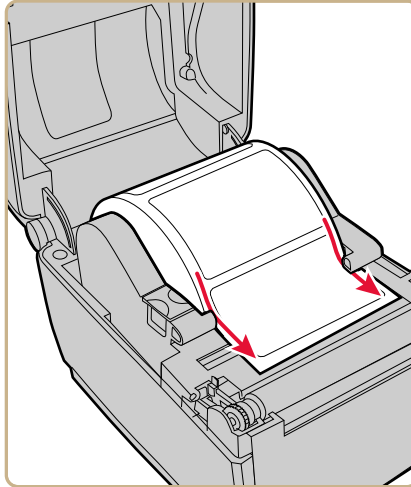

For a PC43t, thread the media through the media guides and past the front of the printer. To adjust the width of the media guides, slide the guides as needed to fit your media.

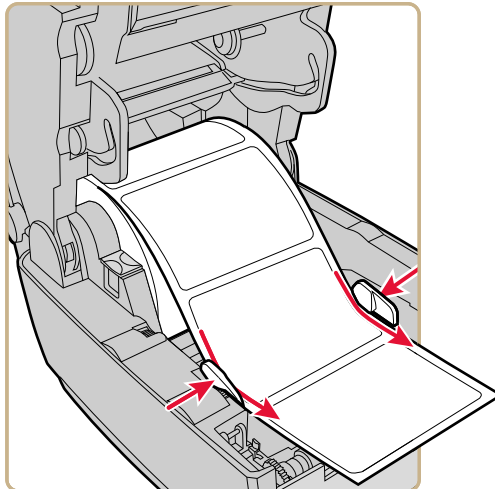

- 6** Close the printer lid until it snaps shut.
- 7** Turn the printer on and configure the feed adjust settings.

About Cut-Off Printing

In cut-off printing, each label is automatically cut from the media roll immediately after the label is printed. You can print on non-adhesive, continuous label stock. You can also use self-adhesive labels with a liner, but you must cut only the liner.



Caution: You must not use the cutter to cut through any kind of adhesive, or other soft material, that may stick to the cutting parts and render the cutter inoperable or even damage the electric motor.

The cutter module includes the top of form sensor. You can also install the optional cutter tray accessory, which holds up to 20 labels or tickets.

After you load media, you need to configure the cutter and the feed adjust settings. You may need to adjust the recommended values slightly depending on your media type, supply method, and roll sizes, or because of individual differences between printers.



Note: Feed adjust values for simulator command languages like ESim, ZSim, and DSim are preset.

Recommended Feed Adjust Values for Cut-Off Printing

Printer	Setting	203 dpi	300 dpi	Distance
PC43d	Start Adjust	-294	-434	-36.80 mm (-1.45 in)
	Stop Adjust	170	251	21.3 mm (0.84 in)
PC43t	Start Adjust	-372	-550	-46.60 mm (-1.45 in)
	Stop Adjust	264	389	33 mm (0.84 in)

Load Media for Cut-Off Printing

Cut-off printing is supported only by the PC43 printer with the cutter module installed.

- 1** Pull one or both of the printer latches toward the front of the printer and lift the printer lid.

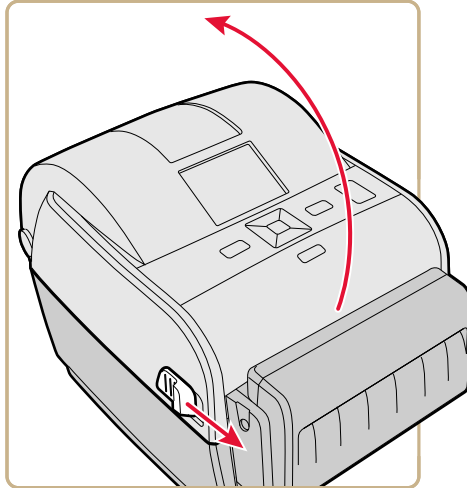

- 2** If there is an empty media core in the media compartment, remove the core.
- 3** If you are going to load the same size media, continue with the next step.

If you are using large rolls of media stored outside the printer, such as in an external media holder, feed the media through the external media feed slot.

Chapter 2 – Set Up the Printer

To adjust the media holders for a different media size:

- a Pull the locking tab up.

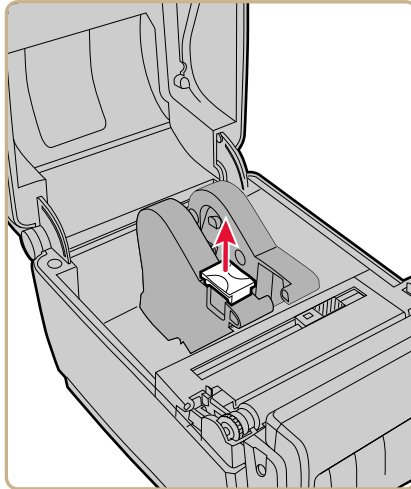

- b Slide the media holders to adjust the distance between them, and place the media roll between the holders.

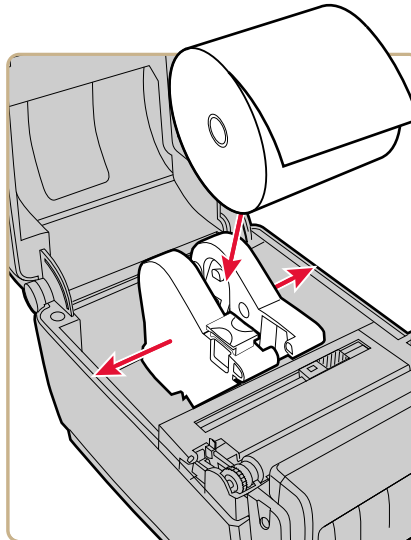

- c** Make sure the media holders are snug against the sides of the media roll, and press the tab down to lock the holders in place.

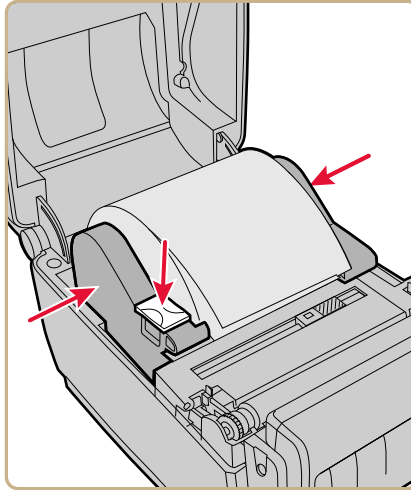

- 4** For the PC43d, thread the media under the tip guides on the media holders.

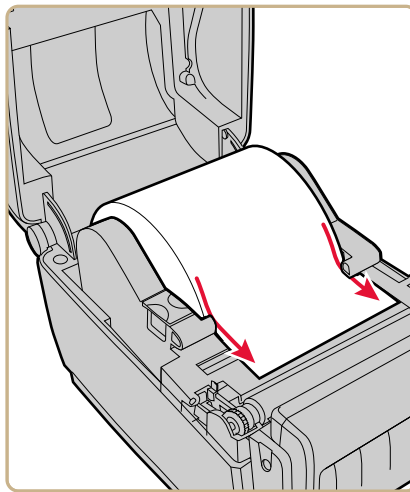

Chapter 2 – Set Up the Printer



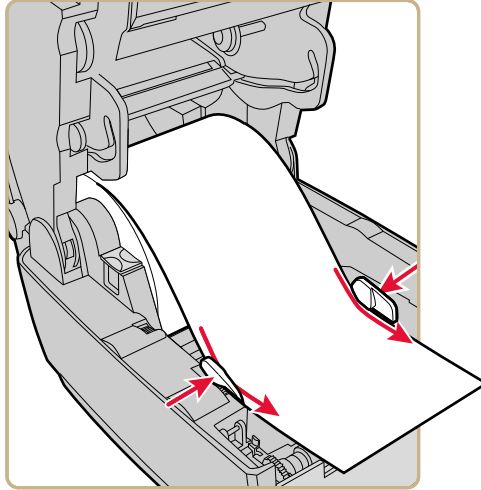

For the PC43t, thread the media through the media guides. To adjust the width of the media guides, slide the guides as needed to fit your media.

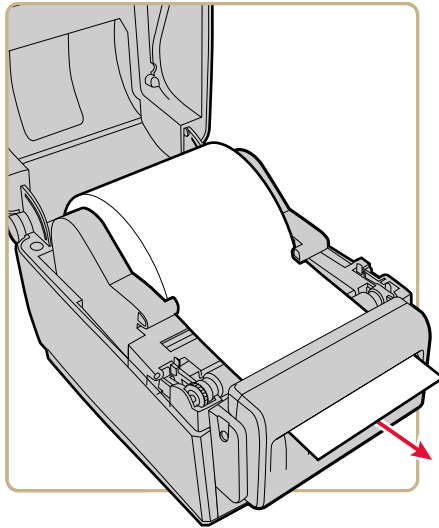

- 5 Thread the media into the slot in the cutter accessory and out through the front of the cutter.



- 6 Close the printer lid until it snaps shut.

- 7 Turn the printer on and configure the cutter:
 - If you have an icon printer, use PrintSet 5 to configure the cutter.
 - If you have an LCD printer, continue with the next step.
- 8 After the printer finishes starting up, press .
- 9 Select **Settings > Printing > Cutter**.
- 10 In the Cutter Control options, select **Automatic**.
- 11 Press  or . A “Save Changes?” message appears.
- 12 Press  to save your changes and exit the Settings menu.
- 13 Configure the feed adjust settings.

About the Label Dispenser

The label dispenser accessory, which includes the Label Taken Sensor, removes the liner from self-adhesive label stock as each label is printed. You manually remove the label at the front of the printer.

After you load media, you need to configure the feed adjust settings. You may need to adjust the recommended values slightly depending on your media type, supply method, and roll sizes, or because of individual differences between printers.



Note: Feed adjust values for simulator command languages like ESim, ZSim, and DSim are preset.

Recommended Feed Adjust Values for the Label Dispenser

Printer	Setting	203 dpi	300 dpi	Distance
PC23d	Start Adjust	-117	-173	-14.70 mm (-0.58 in)
	Stop Adjust	3	5	-0.46 mm (0.02 in)
PC43d	Start Adjust	-126	-186	-15.8 mm (-0.62 in)
	Stop Adjust	2	3	0.3 mm (0.01 in)
PC43t	Start Adjust	-125	-185	-15.7 mm (-0.62 in)
	Stop Adjust	16	24	2.1 mm (0.08 in)

Load Media for the Label Dispenser

To use the label dispenser accessory for printing, you print labels on self-adhesive label stock with a liner. As each label is printed, the label is automatically peeled from the liner and is presented at the front of the printer for manual removal.

- 1** Pull one or both of the printer latches toward the front of the printer and lift the printer lid.

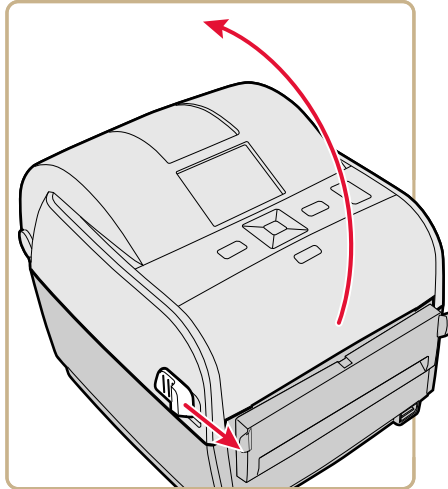

- 2** If there is an empty media core in the media compartment, remove the core.
- 3** If you are going to load the same size media, continue with the next step.

If you are using large rolls of media stored outside the printer, such as in an external media holder, feed the media through the external media feed slot.

To adjust the media holders for a different media size:

- a** Pull the locking tab up.

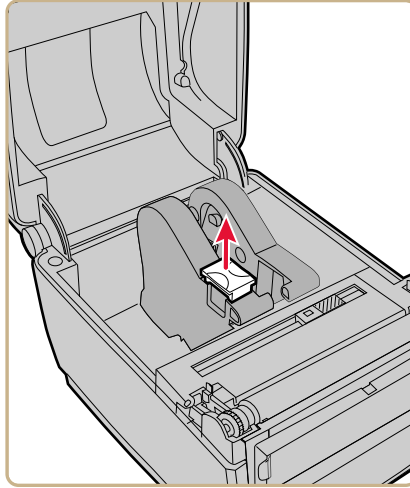

- b** Slide the media holders to adjust the distance between them, and place the media roll between the holders.

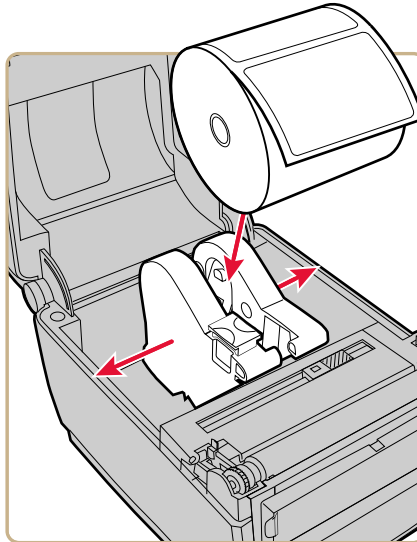

- c Make sure the holders are snug against the sides of the media roll, and press the tab down to lock the holders in place.

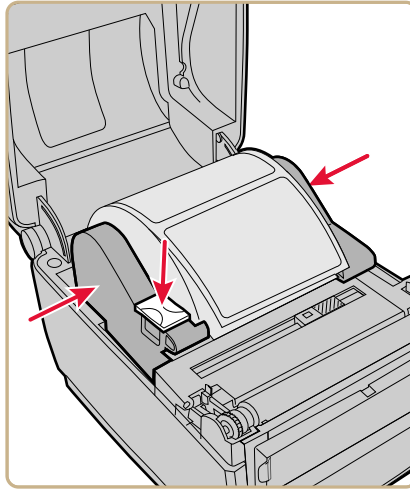

- 4 If you are using notched or black mark stock, slide the gap sensor so the notches or marks pass over the sensor.

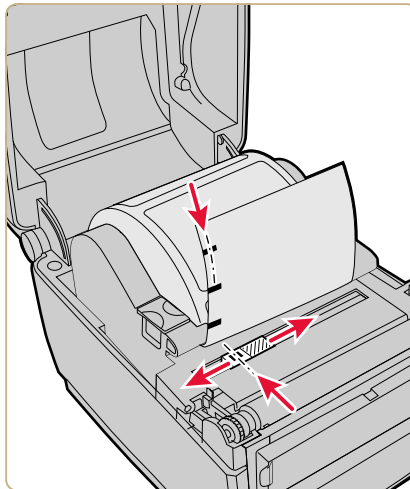

- 5** For the PC43d, thread the media under the tip guides on the holders.

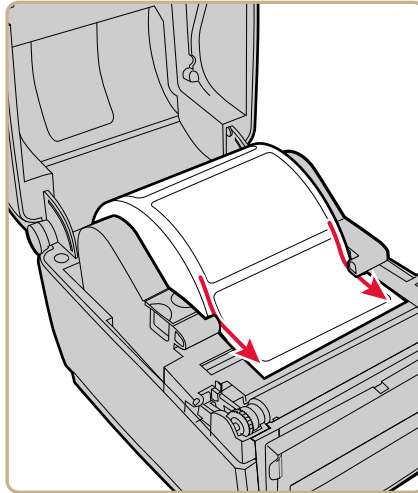

For the PC43t, thread the media through the media guides. To adjust the width of the media guides, slide the guides as needed to fit your media.

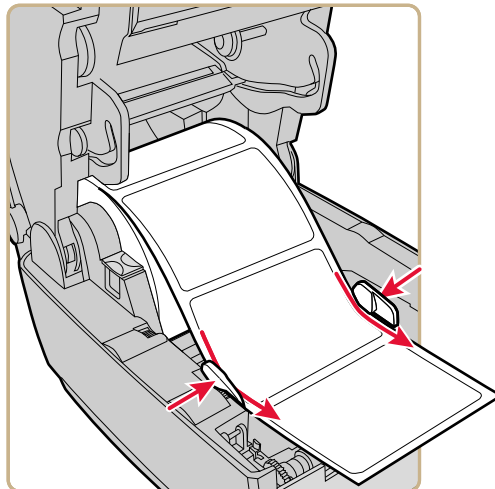

- 6** Open the label dispenser front door.
- 7** Remove the label closest to the end of the liner.

- 8** Route the liner through the slot in the front door of the label dispenser. Do not pull on the media to take up the slack. The liner should be over the roller in the printer and under the roller in the front door of the label dispenser.

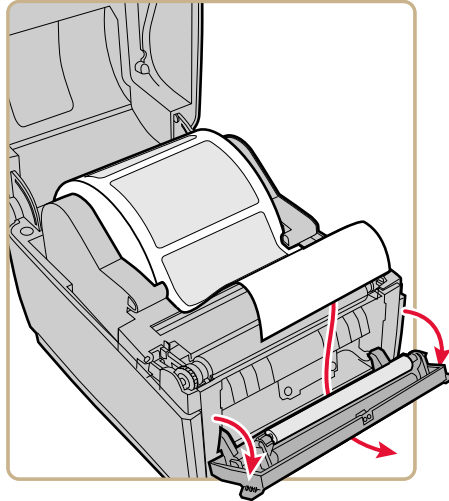

- 9** Close the front door.
- 10** Close the printer lid until it snaps shut.
- 11** Turn the printer on and configure the feed adjust settings.

Load External Media

To use large rolls of media or tag stock (up to 8-in diameter), you can load the media from outside the printer.

- 1 Place the media behind the printer.
- 2 Feed the media into the printer through the external media feed slot.

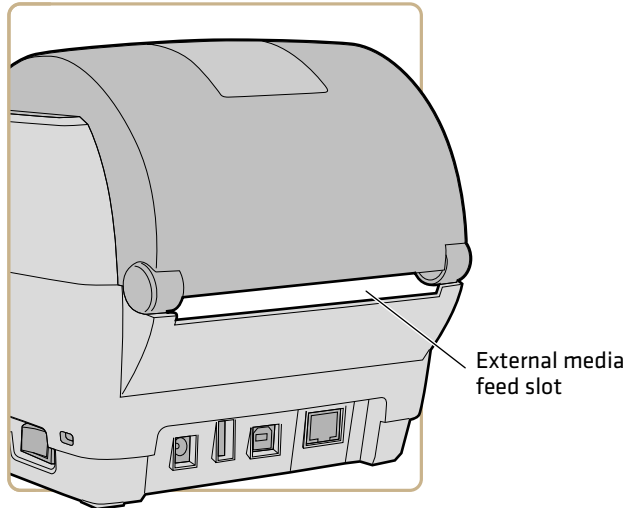

- 3 Thread the media through the media holders or media guides as you would for media installed inside the printer.

Load Ribbon



Note: The PC43t only supports “ink out” operation.

- 1 Press the printer latches toward the front of the printer and open the printer lid.

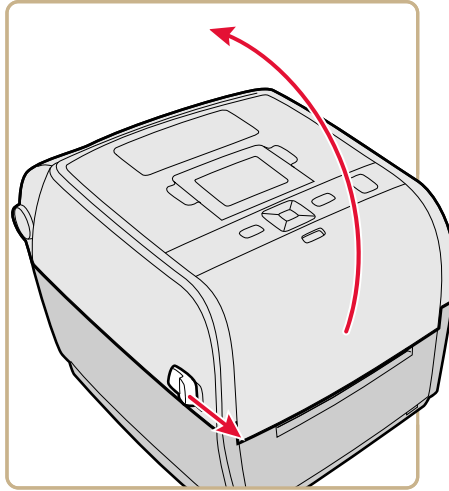

- 2 If there is an empty ribbon core in the media compartment, remove the core and set it aside.
- 3 Remove and discard the full ribbon takeup core.

- 4 Place the new ribbon roll between the rear ribbon holders. The ribbon should come off the roll as shown in the illustration.

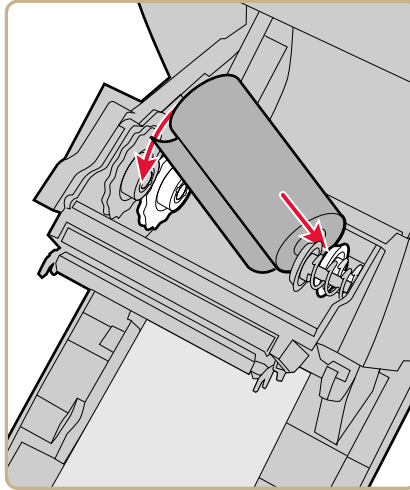

- 5 Place the takeup core between the front takeup core holders.

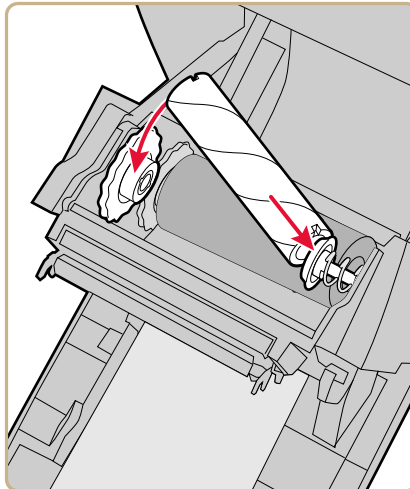

- 6 Attach the end of the ribbon to the takeup core.

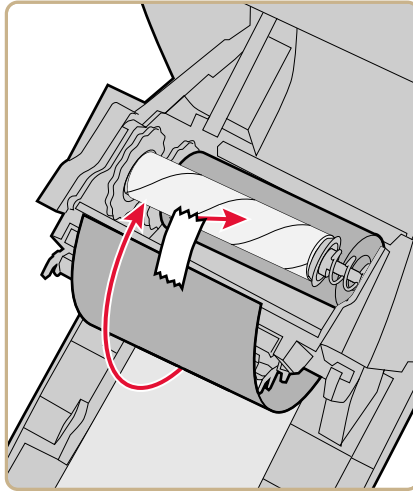

- 7 Turn the slack-wheel to take up slack in the ribbon.

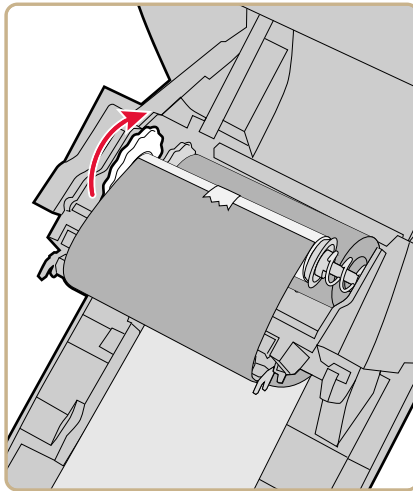

- 8 Close the printer lid until it snaps shut.

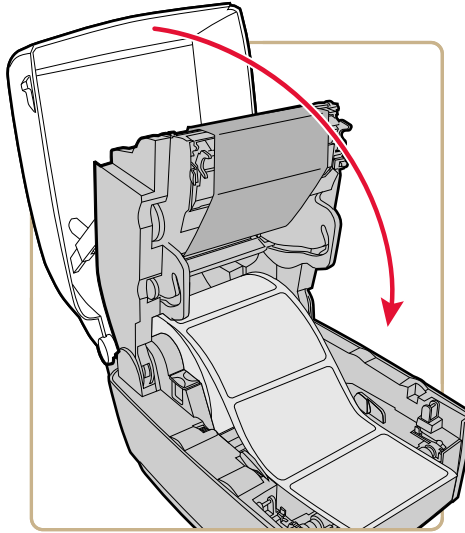

- 9 If you have already configured the printer for thermal transfer printing, continue with the next step. Otherwise, from the printer Main Menu, select **Settings > Printing > Media > Print Method > Ribbon (TTR)**.

For an icon printer, you must use the printer web page or Intermec PrintSet 5 to configure thermal transfer printing.

- 10 Save your changes.

Use the Notchless Ribbon Core Adapter

Use the optional ribbon core adapter to load media without notches in the core. The ribbon core adapter is sold separately. For information on purchasing this accessory, contact your local sales representative.

- 1 Insert one adapter into the media core and one adapter into the takeup core.

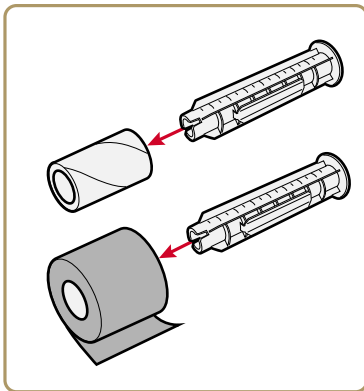

- 2 Center the media roll and takeup core on the adapter.

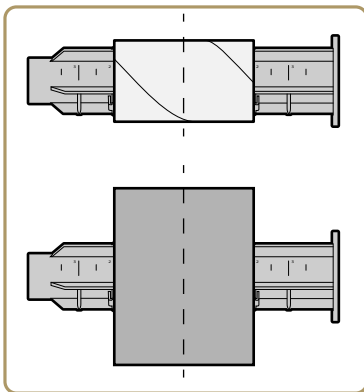

- 3 Press the release button and raise the print mechanism.

- 4** Place the ribbon roll and adapter into the rear media holders.

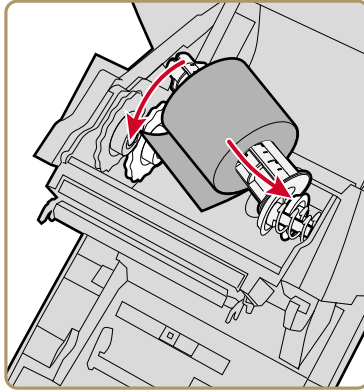

For “ink out” operation (default), the ribbon should come off the back of the roll.

- 5** Place the takeup core and adapter between the front media holders.

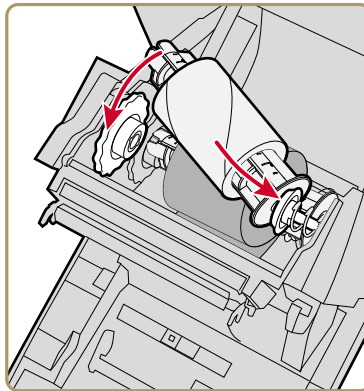

- 6** Route the ribbon under the print mechanism and up to the takeup core.

- 7 Attach the ribbon to the takeup core.

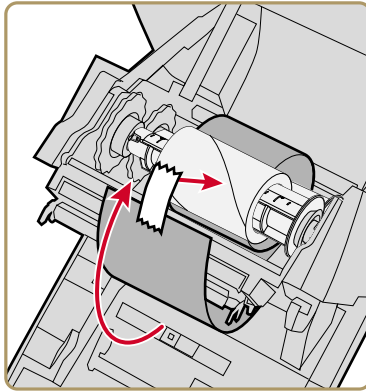

- 8 Turn the slack-wheel to take up slack in the ribbon.

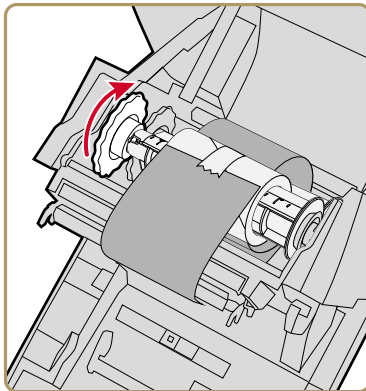

Connect the Printer to Power



Caution: Use only the AC power adapter supplied with the printer. The use of a power adapter not approved by Intermec voids the product warranty and may damage the printer.







- 1 Connect the power adapter to the power port on the rear of the printer.
- 2 Connect the power adapter to AC power. When the adapter is connected to AC power, the green LED in the adapter connector turns on and stays on.

- 3** Press the power switch to turn the printer on. As the printer starts up:
 - a progress bar appears on the LCD printer screen. When the printer has finished starting up, the Ready screen appears, and the blue Ready-to-Work™ indicator turns on and stays on.
 - the icons turn on and then turn off one at a time on the icon panel. When the printer has finished starting up, the blue Ready-to-Work indicator turns on and stays on.

If a condition occurs that will prevent printing, the Ready-to-Work light blinks.

Use the Setup Wizard

This section explains how to use the Setup Wizard to configure the LCD printer. You must configure the printer this way after turning it on for the first time, after upgrading the firmware, or after resetting all defaults.

- 1** Connect the printer to power and press the Power switch. When the printer is ready, the Setup Wizard starts.
- 2** Select the settings you want from the menus in the Setup Wizard.
 - Use  or  to select different items in a list.
 - If the item you selected requires you to select an option from a preset list, press  or  to scroll through the list items.
 - Press  to select a highlighted item.
 - Select  and press  to continue to the next screen.

How to Set Up an Icon Printer

If your printer has the icon front panel, follow these guidelines for connecting and setting up the printer. The way you set up an icon printer depends on whether you plan to connect the printer to your network or to a single PC.

If your network automatically assigns communications parameters (such as IP addresses) to devices, you can set up the printer through the printer web page. The printer web page allows you to configure all settings, print test labels, and perform other management and setup tasks.

If your network does not automatically assign communications parameters to devices, or if you plan to connect the printer to a single PC, you must use the PrintSet 5 application to set up the printer.

Set Up an Icon Printer without a Network Option

Follow this procedure to set up an icon printer that does not have the Ethernet or Wi-Fi network options. You configure printer settings through the Windows print driver.



Note: Before you begin, use InterDriver to install the driver for the printer on your desktop PC.

- 1** Make sure the printer is turned on and connected to your desktop PC with a USB cable.
- 2** On your desktop PC, select **Start > Devices and Printers**.
- 3** In the Printers and Faxes section, right-click the printer and select **Printing preferences**.

You can change printer settings in the Printing Preferences dialog box. For more information on the Windows print driver settings, click **Help**.

Set Up an Icon Printer with Ethernet

If your icon printer includes the Ethernet network option, follow this procedure to obtain the printer IP address and configure settings through the web page interface.



Note: Before you begin, use InterDriver to install the driver for the printer on your desktop PC.

- 1 Connect the printer to your Ethernet network and turn the printer on. Wait until all the icons turn off.
- 2 Press and hold the **Feed** button. The printer feeds one label. When the printer starts feeding a second label, release the **Feed** button. The printer prints two configuration labels.
- 3 Find the IP address on the second configuration label.
- 4 On your desktop PC, open a web browser and browse to the IP address. The printer web page appears.

You can configure printer settings through the web page interface.

Set Up an Icon Printer with Wi-Fi

If your icon printer includes the Wi-Fi network option, follow this procedure to enable Wi-Fi communications, obtain the printer IP address and configure settings through the web page interface.



Note: Before you begin, use InterDriver to install the driver for the printer on your desktop PC.

- 1 Make sure the printer is turned on and connected to your desktop PC through a USB cable.
- 2 On your desktop PC, start PrintSet 5 and use the application to determine the printer IP address.

For help, see the PrintSet online help.

- 3 Open a web browser and browse to the IP address. The printer web page appears.

You can configure printer settings using the web page interface.



Calibrate the Media Feed and Print Test Labels on the Icon Printer

For the icon printer, follow this procedure to automatically calibrate the media feed and print test labels.

- 1 Make sure that the printer has media and ribbon (if necessary) installed.
- 2 Turn off the printer.
- 3 Turn the printer back on. All the LEDs light up. As the printer starts up, the LEDs turn off one by one, starting with the bottom right LED.
- 4 When the last two LEDs (Maintenance and Bluetooth) are lit, press and hold . The printer feeds a few labels as it automatically adjusts the media feed, and then prints two test labels with media and communications settings.

Set the Command Language with the Print Button

If you have an icon printer, you can use the **Print** button to set the printer command language.

- 1 Make sure that the printer has media and ribbon (if necessary) installed.
- 2 Turn off the printer.
- 3 Turn the printer back on. All the LEDs light up. As the printer starts up, the LEDs turn off one by one, starting with the bottom right LED.
- 4 When the last two LEDs (Maintenance and Bluetooth) are lit, press and hold . The printer feeds a few labels as it automatically adjusts the media feed, and then the test labels start to print.
- 5 Continue to hold . The available printer command languages start to print.
- 6 When you see the language you want to use, release .
- 7 The printer automatically reboots and starts in the command language you selected.

About Test Labels

You can print a test label to check print quality and get configuration information, including lists of the fonts, images, and applications installed on the printer. Use one of these methods to print a test label:



- In Start Up mode
- In Idle mode
- From the Main Menu
- From PrintSet 5

You can also print test labels from the printer web page, which requires a network connection to a desktop PC. You need to know the printer IP address to view the printer web page.

Print a Test Label in Start Up Mode

You can print a test label when you first turn on the printer.

- 1 Make sure that the printer has media and ribbon (if necessary) installed.
- 2 Connect the printer to power and turn on the printer.
- 3 On the icon printer, when the last two LEDs are lit (Maintenance and Bluetooth), press and hold  until the test label starts to print.



On the LCD printer, when the status bar appears, press and hold  until the Media Calibration Wizard appears. Select  and press  to print a label with the current print settings.

Print a Test Label in Idle Mode

You can print a test label when the printer is in Idle mode.





- 1 Make sure that the printer has media and ribbon (if necessary) installed.

- 2 On the icon printer, press and hold  until the test label starts to print.



On the LCD printer, press and hold  until the Media Calibration Wizard appears. To print a label with the current print settings, select  and press .

Print a Test Label from the Main Menu

If you have an LCD printer, you can print a test label from the Main Menu.

- 1 Make sure that the printer has media and ribbon (if necessary) installed.
- 2 From the Ready screen, press .
- 3 Press  to select **Tools** and then press . The Tools menu appears with **Test Labels** selected.
- 4 Press .



- 5 Select **Print Quality**, **Printer Information**, or **Printer Settings**, and then press . A list of available labels appears.
- 6 Select a label to print, and then press .

How to Print on RFID Media

If you have an LCD printer with the optional RFID module installed, you can print on RFID media. Media containing RFID tags is slightly thicker where the RFID tag is located. The slight thickness of this part of the label may affect print quality. For thermal transfer labels, Intermec recommends using high-quality ink ribbon.

To achieve the best possible print quality, follow these guidelines:

- Run the RFID calibration wizard to determine the best Tag Position and Output Power for RFID media.
- If necessary, modify the Tag Position (TAGADJUST variable) to make sure the RFID labels are properly aligned with the antenna.
- Avoid printing on the thickest part of the label when possible.

For help configuring RFID parameters, see the [Intermec Fingerprint Command Reference Manual](#) or the [IPL Command Reference Manual](#).

About RFID Tag Position

Tag Position, also referred to as TAGADJUST, specifies the distance (in dots/mm/in) to move the label to align the tag with the RFID antenna. Positive values move the label forward, and negative values move the label back.

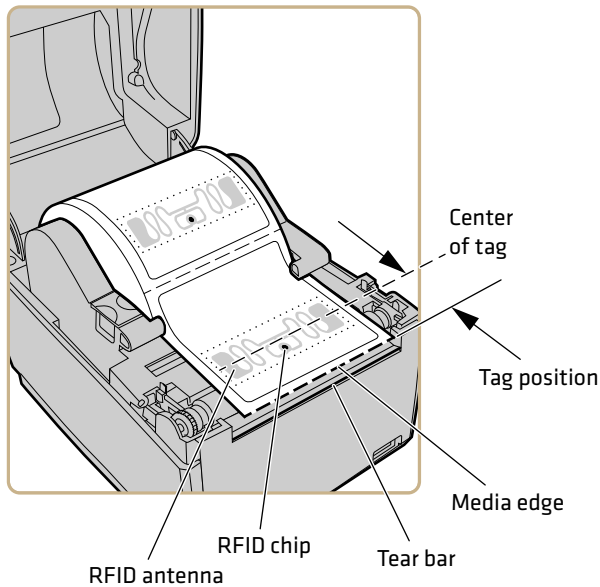

RFID Tag Position

Use one of these methods to calculate Tag Position:

- Run the RFID wizard.
- Manually calculate the Tag Position.

Run the RFID Calibration Wizard

Run the RFID calibration wizard to determine the best Tag Position and Output Power (UHF inlays, only) for RFID media.



Note: After you determine the correct RFID media settings, you can save these settings to a printer profile and load the profile when you need to print on the specific RFID media.

- 1** Make sure the media type and media length are properly configured.
- 2** From the Main Menu, select **Wizard > Calibration > RFID Calibration**.
- 3** To enable the RFID module, select **Enable**.
- 4** Load the RFID media.
- 5** Select **OK**.

When the calibration is complete, the printer displays the RFID Tag Position and Output Power (UHF inlays, only).

Calculate RFID Tag Position

You can perform a manual calculation to come up with an estimate of the RFID Tag Position. Because this value is an estimate, you may need to slightly adjust the calculated value to achieve the best results.

- 1 Make sure Start Adjust and Stop Adjust are set to 0.
- 2 Measure the yChip value, which is the distance between the RFID chip and the media edge aligned with the tear bar.

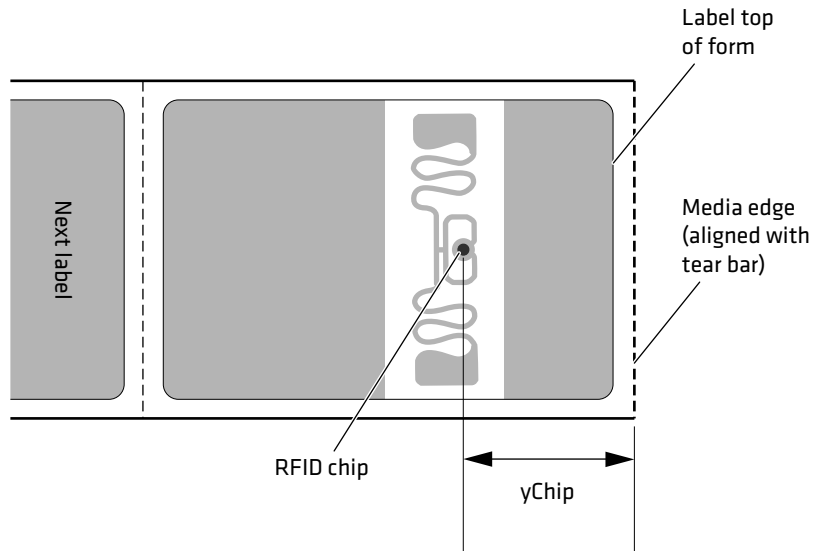

- 3 Note the yAntDist value for your printer:
 - PC23d: 280 dots, 35 mm, 1.378 in
 - PC43d: 260 dots, 33 mm, 1.299 in
 - PC43t: 256 dots, 32 mm, 1.260 in
- 4 Use this formula to calculate the estimated Tag Position:

$$\text{TagPosition} = \text{yChip} - \text{yAntDist}$$

3

Connect the Printer

This chapter explains how to connect the PC23 and PC43 printers to a PC and to an Ethernet or wireless network.

About Printer Drivers

Before you can use the printer with Microsoft Windows printing applications, you need to install printer driver software on the PC. Drivers enable the printer to communicate with your PC and with software applications such as Honeywell PrintSet 5.



Note: Although Windows may auto-detect the printer when you connect it to a PC through a USB port, you must still install printer drivers on the PC for correct printer operation.

Install Printer Drivers

Use InterDriver to install printer driver software on your PC. InterDriver is included on the PrinterCompanion CD that shipped with your printer. If you have not yet installed drivers on your PC, run the PrinterCompanion CD and follow the instructions to connect your printer and install the drivers.

If you do not have access to the PrinterCompanion CD but you still need to install driver software, follow this procedure to download InterDriver from the Intermec website and install the drivers.

- 1** Open a web browser and go to www.intermec.com.
- 2** Select **Support > Downloads**.
- 3** Select these items:
 - a** In the Product Category list, select **Printers**.
 - b** In the Product Family list, select **Fixed Printer**.
 - c** In the Product list, select **PC23d, PC43d, PC43t Desktop Printer** and then click **Submit**.
- 4** In the downloads page, click **Intermec InterDriver X.X.X M-X ver. X.XX**. If a Security Warning dialog box appears, click **Run**.
- 5** When asked if you want the program to make changes to your computer, click **Yes**.
- 6** Follow the onscreen instructions in the InterDriver InstallShield wizard.

- 7** When you reach the InstallShield Wizard Complete page, click **Next**. The InterDriver Wizard appears.
- 8** From the Welcome to InterDriver Wizard page, make sure **Install printer drivers** is selected and then click **Next**.
- 9** Follow the onscreen instructions in the InterDriver Wizard.
- 10** When you reach the Completing the InterDriver Wizard page, click **Finish**.
- 11** When the InterDriver Wizard Completed Successfully page appears, click **Next**.
- 12** Follow the onscreen instructions to complete the Post-Setup Tasks.
- 13** When the Installation Complete! page appears, click **Finish**.
The installer unpacks and installs the InterDriver files in the Intermec\InterDriver folder in your program files directory and creates two shortcuts in the Windows Start menu:
 - Intermec > InterDriver > InterDriver Wizard
 - Intermec > InterDriver > Check for Updates

How to Connect the Printer to Your PC

You can connect the printer to your PC using one of these cables:

- USB cable
- USB-to-Serial adapter cable
- USB-to-Parallel adapter cable
- Serial or parallel cable

Connect the Printer Using a USB Cable

The printer supports USB connections to a desktop PC. You do not need to set up any parameters for USB communications.



Note: You must install InterDriver to use a USB connection to a Windows PC. For more information, see the PrinterCompanion CD that came with your printer.

- 1 Download and install the InterDriver software on your PC.
- 2 Connect one end of the USB cable to the USB device port on the back of the printer, and connect the other end to your PC. A “USB Host Connected” message appears on the printer screen.

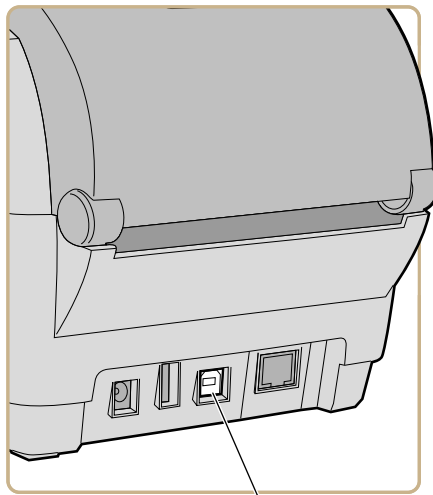

USB device port

Connect the Printer Using a Serial or Parallel Cable

If you have the optional USB-to-Serial adapter cable or USB-to-Parallel adapter cable for the printer, you can connect the printer to the serial or parallel port on a PC.

- 1 Connect the adapter cable to the USB host port on the printer.

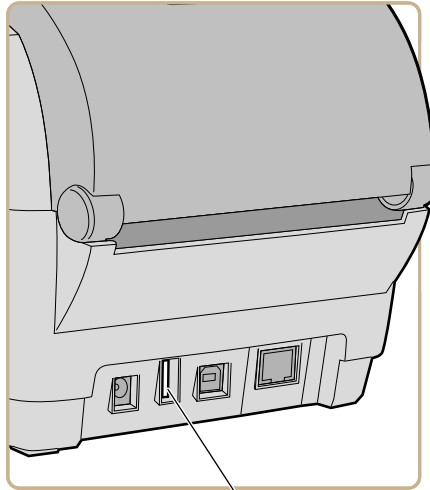

USB host port

- 2 For a USB-to-Serial adapter, connect the adapter cable to the serial port on your PC. Continue with the next step.

For a USB-to-Parallel adapter, connect the adapter cable to the parallel port on your PC. The printer is ready to communicate with your PC.

- 3 If you are using an LCD printer, from the printer Main Menu select **Settings > Communications > Serial** and change settings as necessary.

If you are using an icon printer, you need to configure settings through an application such as PrintSet 5.

How to Connect the Printer to Your Network

You can connect the printer to your network using the:

- Ethernet interface.
- Wi-Fi + Bluetooth wireless interface.

These network interfaces provide features such as security, FTP server, web page, and Alert handling.

Connect the Printer to an Ethernet Network

If your printer has an Ethernet module, you can connect it to your wired network. For help installing this accessory, see the [PC23d, PC43d, and PC43t Ethernet Module Installation Instructions](#).

By default, the printer supports DHCP networks. If you are not using a DHCP network, you need to configure wired Ethernet settings by using Intermec PrintSet 5 through a USB connection to the printer.

- 1 Connect an Ethernet cable to the Ethernet port on the rear of the printer and to your network.

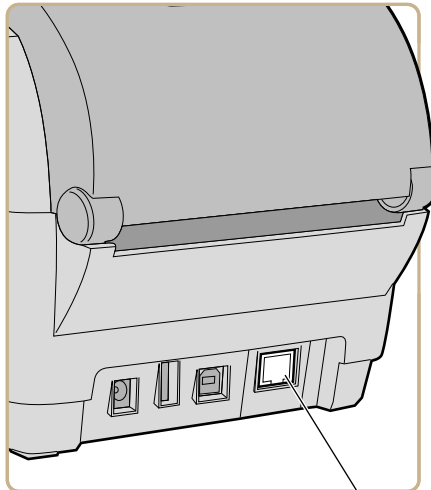

Ethernet port

- 2** Get the IP address for your printer:
 - For an LCD printer, from the Main Menu select **Settings > Communications > Ethernet** and find the IP address.
 - For an icon printer, press and hold  until the test label with the IP address starts to print.
- 3** Configure the necessary Ethernet settings:
 - For an LCD printer, from the Main Menu select **Settings > Communications > Ethernet**.
 - For an icon printer, configure the Ethernet settings through PrintSet 5 or the printer web page.

About Wi-Fi Communications

The printer supports Wi-Fi communications when the optional Wi-Fi/Bluetooth module is installed.

You can configure Wi-Fi communications:

- by using the wireless wizard in the printer Main Menu.
- from the printer web page. You need to know the printer IP address.
- from the printer Main Menu if your printer has a graphical interface.

By default, the printer supports DHCP networks. If you are not using a DHCP network and you do not know the printer IP address, you need to configure Wi-Fi settings by using PrintSet 5 through a USB connection to the printer, or by sending commands through a serial connection.

Connect the Printer to a Wireless Network

Before you begin, you should be familiar with the settings you need for your network.

If you are using a DHCP network, turn the printer on. The printer automatically connects to the wireless network.

Chapter 3 – Connect the Printer

For a printer with the LCD interface, the Wi-Fi Connection icon shows the status of the connection.

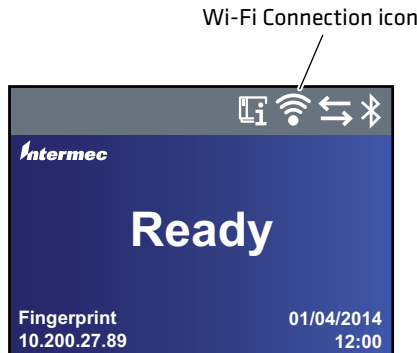

For a printer with the icon interface, the Wi-Fi icon turns on to show that Wi-Fi is enabled.

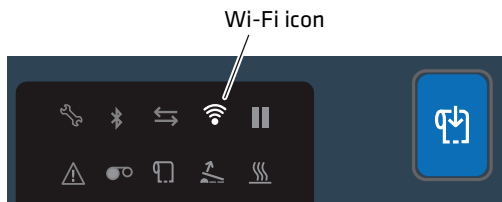

If you are not using a DHCP network, follow the next procedure to manually assign network settings (such as the printer IP address) to a printer with the LCD interface.



Note: If you are using an icon printer and you do not know the printer IP address, you need to use PrintSet 5 with a USB connection to a PC to configure wireless network settings for a non-DHCP network.

- 1 From the printer Ready screen, press . The Main Menu appears.

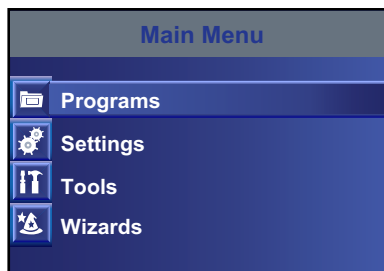

2 Select **Settings > Communications > Wireless 802.11**.

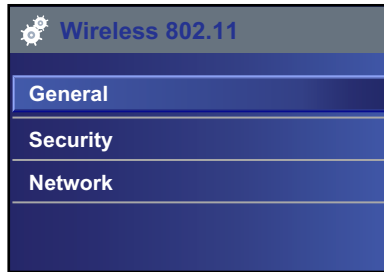

3 Select **General** to configure these wireless network settings:

- Network Name (SSID)
- Network Type
- Roaming
- Power Mode
- Channel (for Ad Hoc mode only)
- Hidden SSID

Select **Network** to configure these settings:

- IP Assignment Method (for IPv4 or IPv6 networks)
- IP address
- Subnet mask and default router

Select **Security** to configure all wireless network security settings.

4 Change settings as needed for your network.

5 When you are finished, save your changes. The printer immediately attempts to connect to your network.

Configure Wi-Fi Communications from the Printer Web Page

You can use the printer web page to configure wireless communications on the printer.



Note: To configure the printer from the web page, the printer must be turned on and connected to your Wi-Fi or Ethernet network.

- 1 On your PC, open a browser.
- 2 In the **Location** or **Address** bar, type the printer IP address and press **Enter**. The printer web page appears.
- 3 Click **Login**. The Login page appears.
- 4 Type your **Username** and **Password** and click **Login**. The default username is `itadmin` and the default password is `pass`.
- 5 Click the **Configure** tab.
- 6 Click **Communications** > **Wireless 802.11**. The Wireless 802.11 page appears.

The screenshot shows the Intermec printer web interface. The top navigation bar includes 'Home', 'Configure', 'Manage', 'IPrint', 'System Information', 'Services', and 'Contact'. The 'Configure' tab is active. On the left, a sidebar menu shows 'Communications' expanded to 'Wireless 802.11'. The main content area is titled 'Wireless 802.11' and contains two sections: 'General' and 'Security'. The 'General' section has fields for Network Name (SSID), Network Type, Roaming, Power Mode, Channel, and Hidden SSID. The 'Security' section has fields for Security Type, Association, Pre-Shared Key, Network Key Index, Network Key 1, Network Key 2, Network Key 3, Network Key 4, User Name, and Password. Buttons for 'Default Settings', 'Save', and 'Save As Profile' are visible at the top right of the configuration area.

- 7 Change settings as needed, or click **Default Settings** to restore all default Wireless 802.11 settings.
- 8 Click **Save** when you are done.

About Bluetooth Communications

The printer supports Bluetooth communications when the optional Wi-Fi/Bluetooth module is installed. When Bluetooth is enabled, you can connect the printer to other Bluetooth devices, such as bar code scanners and keyboards. You can also make the printer discoverable by Bluetooth-enabled devices such as mobile computers.



Note: To connect to the printer from a Bluetooth-enabled mobile computer, you may need to configure Bluetooth settings on the printer before you try to discover the printer from the mobile computer.

When the Wi-Fi/Bluetooth module is installed:

- the Bluetooth icon appears in the status bar on the LCD printer screen.
- the Bluetooth icon turns on in the icon printer interface.

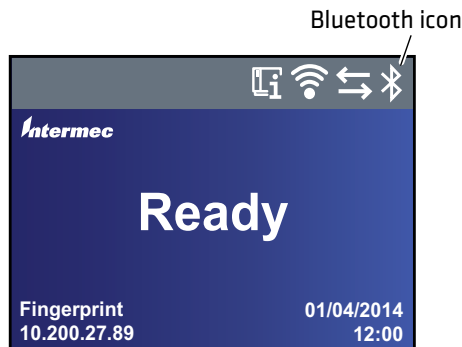

Bluetooth Icon in LCD Interface

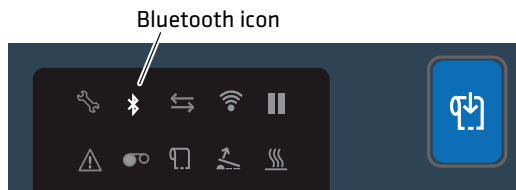

Bluetooth Icon in Icon Interface

The icon is white when the Bluetooth connection is active, and gray when the connection is inactive or disabled.

Connect to a Bluetooth Device by Reading a Bar Code

To connect a Bluetooth-enabled bar code scanner to the printer, use the scanner to read the “Scan to Connect” bar code.

- 1** Make sure your printer is ready to print.
- 2** On your desktop PC, start a web browser.
- 3** In the address field, type the printer IP address and then press **Enter**. The printer web page appears.
- 4** Click **Services** and then select **Print Test Labels > Printer Settings**.
- 5** In the Printer Settings screen, locate the Bluetooth Settings label and click **Print**. The printer prints the Bluetooth Settings label.
- 6** Make sure your Bluetooth scanner is turned on and discoverable, and that the device is in range of the printer.
- 7** Use the scanner to read the “Scan to Connect” bar code on the Bluetooth Settings label. The printer attempts to connect to the scanner.

Connect to a Bluetooth Device Using a Wizard

If your printer has the LCD interface, you can also use the Bluetooth wizard to discover and connect to a Bluetooth device, such as a keyboard.

- 1** Make sure your Bluetooth device is turned on and discoverable, and that the device is in range of the printer.
- 2** From the printer Ready screen, press . The Main Menu appears.
- 3** Select **Wizards > Communications > Bluetooth**.
- 4** Follow the instructions to discover and connect to your Bluetooth device.

If you are unable to connect to the Bluetooth device, change the printer Bluetooth settings or move the Bluetooth device closer to the printer.

Configure Bluetooth Communications from the Main Menu

This section explains how to configure Bluetooth settings from the printer Main Menu. You may need to configure these settings if you want to connect to a mobile computer through Bluetooth.

- 1 From the Ready screen, press . The Main Menu appears.
- 2 Select **Settings** > **Communications** > **Bluetooth**.
- 3 Change settings as needed for your Bluetooth device.
- 4 When you are finished, save your changes and restart the printer.

Configure the Printer from the Web Page

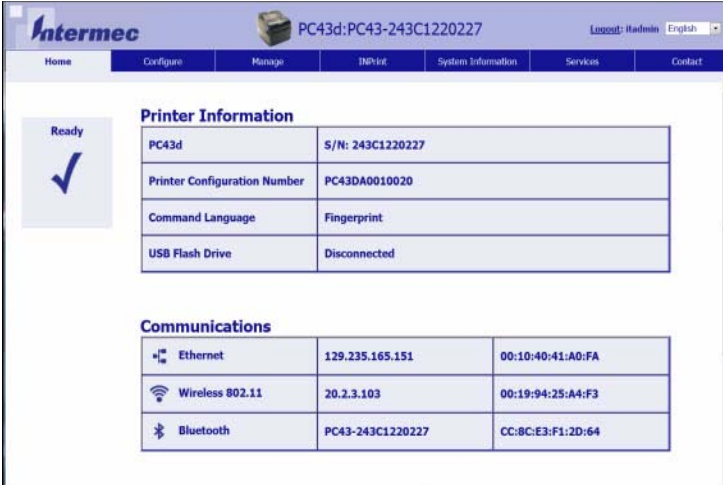

If you are using Ethernet or Wi-Fi communications, you can change printer configuration settings from the printer web page. You should have already connected your printer to your network and obtained an IP address.

- 1 Open a web browser on your PC.
- 2 In the **Location** or **Address** bar, type the printer IP address, and then press **Enter**. The printer web page appears.



The screenshot shows the Intermec printer web page for model PC43d. The page includes a navigation menu with options like Home, Configure, Manage, IN/Out, System Information, Services, and Contact. A 'Ready' status indicator with a checkmark is visible on the left. The main content area is divided into two sections: 'Printer Information' and 'Communications'.

PC43d	S/N: 243C1220227
Printer Configuration Number	PC43DA0010020
Command Language	Fingerprint
USB Flash Drive	Disconnected

 Ethernet	129.235.165.151	00:10:40:41:A0:FA
 Wireless 802.11	20.2.3.103	00:19:94:25:A4:F3
 Bluetooth	PC43-243C1220227	CC:8C:E3:F1:2D:64

- 3 Click **Login** in the upper right corner of the screen. The Login page appears.

- 4** Type your **Username** and **Password** in the entry fields, and then click **Login**. The default username is `itadmin` and the default password is `pass`.
- 5** Click **Configure**. The Configuration Summary page appears.
- 6** To see a complete list of printer settings, click **Configuration Summary**.

To configure printer settings, use the links in the navigation pane:

- For serial port, Wi-Fi, or Bluetooth settings, click **Communications**.
 - For media, print quality, or performance settings, click **Printing**.
 - For display, audio, service, and general settings, maintenance alert message triggers, or to enable and disable 802.11 and Bluetooth or the virtual COM port, click **System Settings**.
 - To set conditions that trigger error, warning, and information alert messages, click **Alerts**.
 - For network-related settings such as web and email server information, or if you are using a network management application such as Intermecc SmartSystems, click **Network Services**.
- 7** Change settings by typing in the fields or by selecting an item from a list.
 - 8** To save your changes on this page, click **Save**. After your changes are saved, you can click **Save As Profile** to create a configuration profile including your changes that you can load at any time.
To reset all values and options on the page to the default settings, click **Default Settings**.

About the USB Host Port

You can use the USB host interface port on the printer to connect these peripheral devices:

USB Peripheral Devices

Device	Description
Keyboard	Use a standard USB keyboard to send Fingerprint printer language commands directly to the printer or to enter information if you are running a Smart Printing application.
Bar code scanner	Use Intermec USB bar code scanners for data input with a Smart Printing application. The printer also supports other USB scanners that use a generic keyboard driver.
USB storage device	Use a USB storage device to load applications, configuration files, fonts, and images into the printer memory, or to perform firmware upgrades. You can also save configuration files to a USB storage device for upload to a printer. The USB storage device must have a single partition and be formatted as FAT16 or FAT32.

You can also connect a peripheral device through the USB-to-Serial or USB-to-Parallel adapter cable accessories. For information, contact your local sales representative.

Connect a USB Device

The printer has two USB host ports that you can connect a USB device to.

- 1 If you are connecting a USB storage device, make sure the device has a single partition and is formatted as FAT16 or FAT32.

- 2 Connect the device to one of the USB host ports.

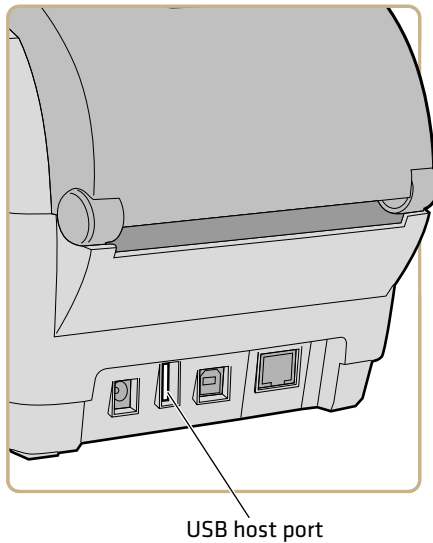
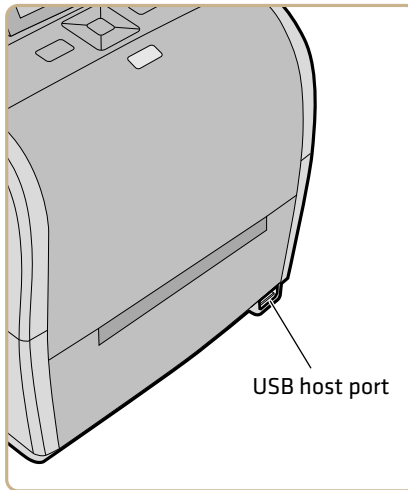

- 3 If you connected a USB storage device to an LCD printer, select **Tools > USB Menu** for more options.

4

Configure the Printer

This chapter explains how to view and change printer settings by using the Main Menu or the printer web pages.

About Printer Configuration Settings

Printer configuration settings determine how the printer operates.

Printer Configuration Settings

Setting Type	Description
Communications	All communications and network settings: <ul style="list-style-type: none">• Serial (appears when using serial connection to PC. Includes virtual COM port settings.)• Ethernet (appears when Ethernet module is installed)• Wireless 802.11 (appears when Wi-Fi/Bluetooth module is installed)• Bluetooth (appears when Wi-Fi/Bluetooth module is installed)
Printing	Configuration settings for media (such as media width and length), print quality, and performance.
System Settings	Global system settings including printer name, location, and contact information, display and keyboard input languages, date and time, unit of measure, audio volume, and printer command language. Display settings including brightness, time and date format, menu access permissions, and screen timeout. Enable and disable Wi-Fi, Bluetooth, Ethernet, or virtual COM port communications. Enable and disable services including Intermec SmartSystems, FTP, Telnet, and others. Set maintenance alert values for the printer odometer and other alerts.
Network Services	Enable or disable network services including Intermec SmartSystems, the web or email servers, and others.

How to Configure the Printer

Use one of these methods to view and change printer settings:

- Printer web page
- Main Menu (LCD printers)
- PrintSet 5
- Programming commands
- SmartSystems

View the Configuration Summary

If you are using Ethernet or Wi-Fi communications, you can view a complete summary of all printer configuration settings from the printer web page. You should have already connected your printer to your network and obtained an IP address.



Note: This process may take several minutes depending on the options in your printer and your network connection.

- 1** Open a web browser on your PC.
- 2** In the **Location** or **Address** bar, type the printer IP address, and then press **Enter**. The printer web page appears.
- 3** Click the **Configure** tab.

- Click **Configuration Summary**. The configuration summary appears.



Configure the Printer from the Web Page

If you are using Ethernet or Wi-Fi communications, you can change printer configuration settings from the printer web page. You should have already connected your printer to your network and obtained an IP address.

- Open a web browser on your PC.
- In the **Location** or **Address** bar, type the printer IP address, and then press **Enter**. The printer web page appears.

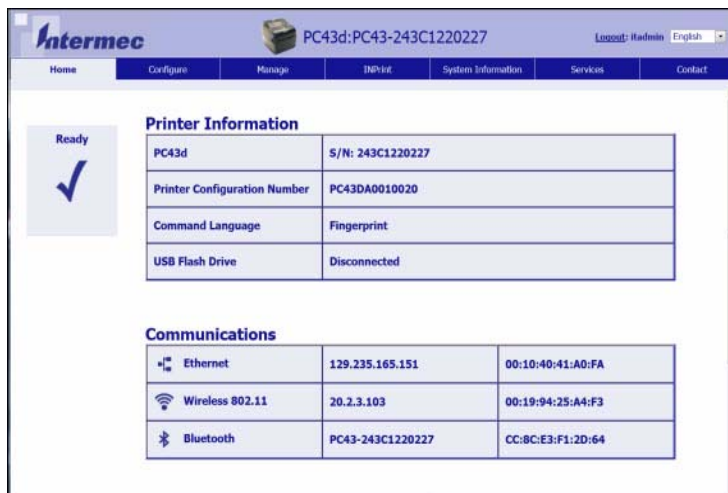



- 3** Click **Login** in the upper right corner of the screen. The Login page appears.
- 4** Type your **Username** and **Password** in the entry fields, and then click **Login**. The default username is `itadmin` and the default password is `pass`.
- 5** Click **Configure**. The Configuration Summary page appears.
- 6** To see a complete list of printer settings, click **Configuration Summary**.

To configure printer settings, use the links in the navigation pane:

- For serial port, Wi-Fi, or Bluetooth settings, click **Communications**.
 - For media, print quality, or performance settings, click **Printing**.
 - For display, audio, service, and general settings, maintenance alert message triggers, or to enable and disable 802.11 and Bluetooth or the virtual COM port, click **System Settings**.
 - To set conditions that trigger error, warning, and information alert messages, click **Alerts**.
 - For network-related settings such as web and email server information, or if you are using a network management application such as Intermec SmartSystems, click **Network Services**.
- 7** Change settings by typing in the fields or by selecting an item from a list.
 - 8** To save your changes on this page, click **Save**. After your changes are saved, you can click **Save As Profile** to create a configuration profile including your changes that you can load at any time.
To reset all values and options on the page to the default settings, click **Default Settings**.

Configure the Printer from the Main Menu

If you have an LCD printer, you can view or change configuration settings from the Main Menu.

- 1 From the Ready Screen, press .
- 2 Select **Settings** and press . The Settings menu appears with **Communications** selected.

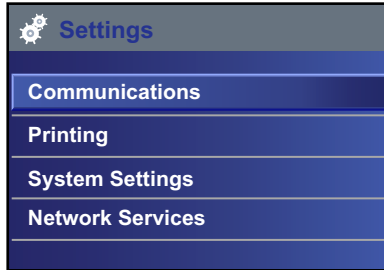

- 3 Select the settings you want to configure and make your changes.
- 4 Save your changes when prompted.

Configure the Printer with PrintSet 5

PrintSet 5 is a printer configuration tool that enables you to easily change your configuration settings. You can also use the setup wizards in PrintSet 5 to guide you through common configuration tasks.

- 1 Make sure that you have Windows XP or later running on your PC.
- 2 Download PrintSet 5 from the Downloads page of the Intermec website at www.intermec.com/products/printers_media/software/index.aspx.
- 3 Connect your printer to your PC using a serial, USB, or network (Ethernet or Wi-Fi) connection.

How to Configure the Printer with Programming Commands

You can change configuration settings by sending programming commands directly from your PC to the printer through a terminal program (such as HyperTerminal), a serial connection, or a network connection.

If your printer uses the Fingerprint programming language, use the SETUP GET command followed by the node, subnode, and parameter setting. For example, here is a Fingerprint example that changes your media setting to labels with gaps:

```
SETUP GET "MEDIA, MEDIA TYPE, LABEL (W GAPS) "
```

You must log in as an itadmin to perform a SET operation, but you do not need to log in to perform a GET operation.

If your printer uses the IPL programming language, this example changes your media setting to labels with gaps:

```
<STX><SI>T1<ETX>
```

For more information on how to change configuration settings with a programming language, see either the [Intermec Fingerprint Command Reference Manual](#) or the [IPL Command Reference Manual](#).

How to Configure the Printer with SmartSystems

You can use SmartSystems to change configuration settings on your printer. The printer ships with the SmartSystems client loaded on it. The console is part of SmartSystems and is available from the Intermec website. To download SmartSystems, go to www.intermec.com/products/smrtsysfoundation/index.aspx.

About Printer Profiles



After you change printer default settings to meet your needs, you can save those settings as a printer profile. The printer supports multiple profiles that you can save and load at any time. For example, you can create one profile to use when you are printing on continuous label stock, and a different profile to use when you are printing on label stock with gaps.

The following printer settings are not saved in a profile:

- IP address for either IPv4 or IPv6 networks
- Media calibration settings for the label stop sensor
- Remote port or remote host values for a remote computer accessing the printer through raw TCP



Save a Printer Profile from the Main Menu

You can save current printer settings for an LCD printer as a printer profile and load that profile on another printer.

- 1 From the Ready screen, press . The Main Menu appears.
- 2 Select **Tools > Profiles**. The Profiles menu appears.
- 3 Select **Save**.
- 4 Select the **Filename** text box and type a name for the profile. The profiles can have up to sixteen characters with no spaces.
- 5 Press  to save your profile name and go back to the Save Profile menu.
- 6 Press  and wait until Complete appears on the screen.

Load a Printer Profile from the Main Menu

You can load a saved LCD printer profile to another printer from the Main Menu.

- 1 From the Ready screen, press . The Main Menu appears.
- 2 Select **Tools > Profiles**. The Profiles menu appears.
- 3 Select **Load**. In the Save Profile menu, select **Filename** and enter a name for the profile of up to sixteen characters (no spaces).
To load a saved profile, select **Load**. In the Load Profile menu, select the profile to load.
- 4 Select the profile you want to load on the printer and press .
- 5 When Complete appears on the screen, press  to return to the Main Menu.

How to Load a Printer Profile with Programming Commands

You can load a saved LCD printer profile to another printer by sending programming commands directly from your PC to the printer through a terminal program (such as HyperTerminal), a serial connection, or a network connection. All commands are case-sensitive.



Note: To load printer profiles that modify communication settings that require itadmin rights, you must log in as an itadmin: RUN “su -p pass itadmin”.

Programming Commands to Load a Printer Profile

Connection	Programming Commands
Printer running Fingerprint	RUN “/system/usr/bin/cfg -o xmlimportset -k /home/user/profiles/myprofile”
Printer running IPL	<STX><ESC>.x,/system/usr/bin/cfg -o xmlimportset -k /home/user/profiles/myprofile<ETX>
Telnet connection over Port 23	/system/usr/bin/cfg -o xmlimportset -k /home/user/profiles/myprofile

About USB Storage Device Directories

You can use a USB storage device to install files, such as applications and fonts on the printer. You need to copy files to specific directories on the USB storage device so that the printer can properly install them.

USB Storage Device File Directories



File Type	Place in This Directory
Application	/apps
Font	/fonts
Form/layout	/forms
Web form	/webforms
Image	/images
Display images	/display
Configuration profile	/profiles
Configuration	/config

USB Storage Device File Directories (Continued)

File Type	Place in This Directory
Fingerprint script	/scripts
Firmware	/firmware
Installation package (UFF resource file)	Root of USB storage device
Start file	Root of USB storage device

Print a File from a USB Storage Device

If you are uploading image files to the printer from a USB storage device, you can print an image file. For example, you can print a file before uploading it to be sure it is the correct file to upload.

- 1 Make sure the USB storage device has a single partition and is formatted as FAT16 or FAT32.
- 2 Insert the USB storage device into the printer USB host port.
- 3 From the Ready screen, press . The Main Menu appears.
- 4 Select **Tools > USB Menu > Print File**. A list of printable files appears.
- 5 Select the file from the list and press . The file prints.



Upload Applications and Files from a USB Storage Device

This topic explains how to upload applications and files to the printer from a USB storage device.

- 1 Copy the files to the appropriate directory on the USB storage device.
- 2 Insert the storage device into the USB host port on the printer. The USB Device menu appears.
- 3 Select **Install Resources** and then press .

- 4 To upload all files to the printer, select **Install All** and then press . All valid files are uploaded to the printer memory.

To upload only one file at a time:

- a Select the type of item you want to upload (**Applications**, **Fonts**, **Forms/Layout**, **Web Forms**, **Images**, **Fingerprint Programs**, or **Display**) and then press .
- b Select the file from the list and then press . The file is uploaded to the printer memory.

Export Applications and Files to a USB Storage Device

This topic explains how to export applications and files from the printer to a USB storage device.





Note: You can only export applications and files that you previously uploaded to the printer memory.

- 1 Make sure the USB storage device has a single partition and is formatted as FAT16 or FAT32.
- 2 Insert the storage device into the USB host port on the printer. The USB Device menu appears.
- 3 Select **Export Resources** and then press . All applications and files in printer memory are copied to the USB storage device.

Export a Configuration File to a USB Storage Device

You can save an .xml configuration file to a USB storage device and install it on other printers.

- 1 Make sure the USB storage device has a single partition and is formatted as FAT16 or FAT32.
- 2 Insert the storage device into the printer USB host port.
- 3 From the Ready screen, press . The Main Menu appears.

- 4 Select **Tools > USB Menu**.
- 5 Select **Configuration**.
- 6 Select **Export Configuration**. A list of the available files appears.
- 7 Select the file to export and then press . The file is exported to the USB memory device.

Install a Configuration File from a USB Storage Device

After you save an .xml configuration file to a USB storage device, you can install it on the printer at any time.



Note: If there is more than one configuration file on the USB storage device, the printer imports the first file found in alphabetical order by file name.

- 1 Insert the USB storage device in the printer USB host port.
- 2 From the Ready screen, press . The Main Menu appears.
- 3 Select **Tools > USB Menu**.
- 4 Select **Configuration**.
- 5 Select **Install Configuration**. The printer imports the configuration file.
 - For most printer languages, the configuration file is imported directly into the working configuration and is not copied to the /config directory.
 - An IPL configuration file is copied to /home/user/config/ipl.
 - An ESim configuration file is copied to /home/user/config/esim.

Upload or Delete Applications and Resources from the Printer Web Page

From the printer web page, use the Manage page to upload or delete applications, fonts, images, label formats, or web forms.



Note: You can only delete applications and resources you downloaded to the printer memory. You cannot delete resident applications or resources, which are installed as part of the printer firmware.

To upload or delete applications or resources from the printer web page, the printer must be turned on and connected to your Wi-Fi or Ethernet network.

- 1 On your PC, start a browser.
- 2 In the **Location** or **Address** field, type the printer IP address and press **Enter**. The printer web page appears.
- 3 Click the **Manage** tab.

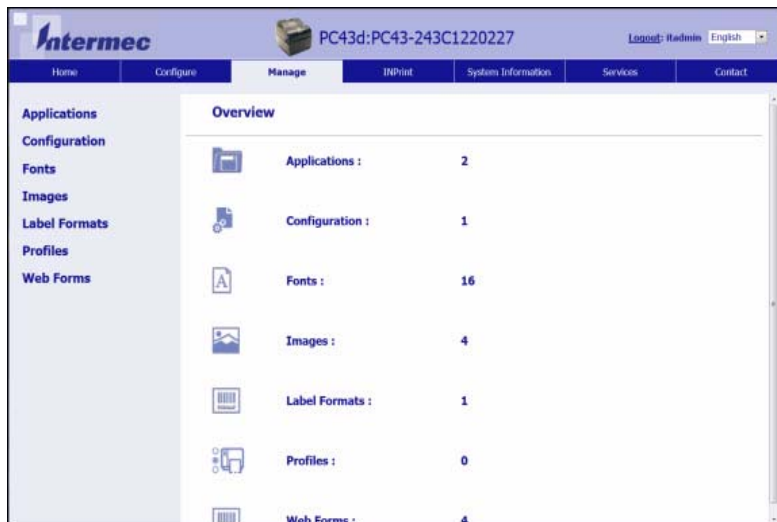

- 4 In the navigation list, click the type of file you want to upload or delete: **Applications**, **Fonts**, **Images**, **Label Formats**, or **Web Forms**. The page for that type of file appears, including a list of **Resident** (Intermec-supplied) files of that type and a list of **Customer Downloaded** files of that type (if any).

Chapter 4 – Configure the Printer

- 5** To upload an application or file to the printer:
 - a** Click **Browse** to locate your application or file.
 - b** Double-click the file to select it.
 - c** Click **Upload**. The application or file uploads to the printer.

To delete an application or file, click the file name in the **Customer Downloaded** list and then click **Delete**. The file is deleted.

5

Troubleshoot the Printer

This section explains how to troubleshoot the PC23 and PC43 printers.

Call Product Support

If you cannot find the answer to your problem in the “Troubleshooting” section, go to the Intermec technical knowledge base (Knowledge Central) at intermec.custhelp.com to review technical information or to request customer support. If you still need help after visiting Knowledge Central, call Product Support.

To talk to an Intermec Product Support representative in the U.S.A. or Canada, call:

1-800-755-5505

Outside the U.S.A. and Canada, go to www.intermec.com and click **Contact Us** to find your local Intermec representative.

Before you call Intermec Product Support, make sure you have this information ready:

- Printer serial number
- Printer configuration number
- Firmware type and version
- Printer command language
- Wireless or serial port settings
- Installed options
- Media settings
- Ethernet settings
- Bluetooth settings

You can find all of this information on the printer web pages or on a test label.

Locate the Printer Configuration and Serial Numbers

The printer configuration and serial numbers can be found on the product label located on the underside of the printer.

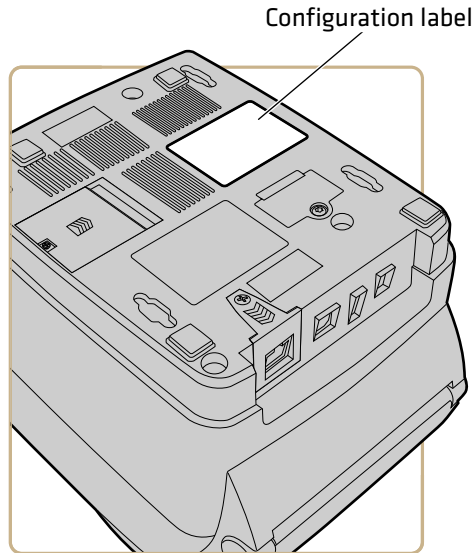

About Printer System Information

Look in the System Information tab in the printer web pages for useful information and statistics on the printer hardware and firmware. This information can be useful when you contact Intermec Product Support for assistance or troubleshooting.



Note: The printer must be connected to an Ethernet or wireless network to view system information in the printer web page.

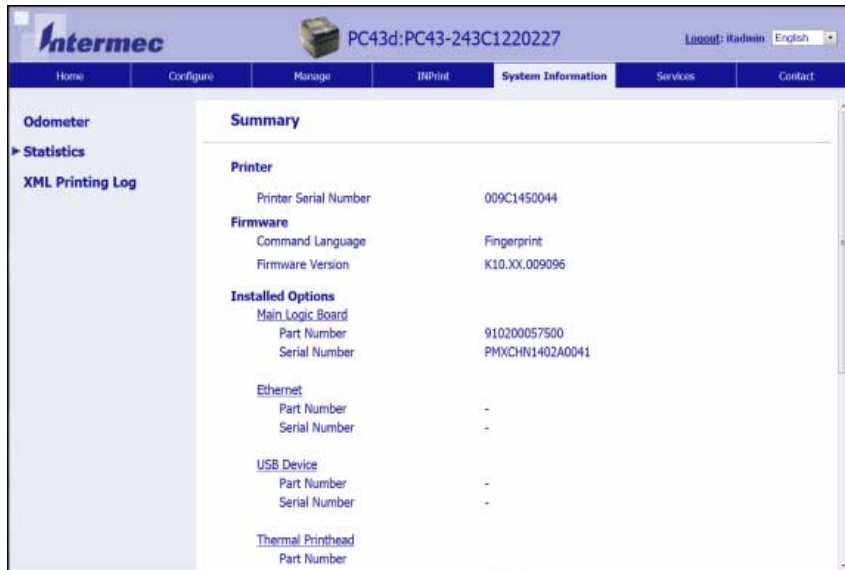

System Information Tab in Printer Web Pages

View Printer Statistics

If your printer is connected to an Ethernet or Wi-Fi network, you can view printer statistics in the printer web page.

- 1 On your PC, open a browser.
- 2 In the **Location** or **Address** bar, type the printer IP address and press **Enter**. The printer web page appears.
- 3 Click the **System Information** tab.
- 4 Click **Statistics**.

- 5** Click a category to see more information. For example, click **Print Statistics** to see the number of labels printed and odometer values.

Statistic	Description
System information	Printer uptime and CPU usage, firmware and kernel versions, printer configuration and serial numbers, flash and RAM memory information.
Print Statistics	Total labels printed, RFID tag success rate, odometer values, total distance printed (printer and current printhead).
Supply	Printhead, media, and ribbon information.
Hardware Options	Input/output devices, serial port information.
Administration	Failed login tries, user information.
Network Interfaces	MAC address, TCP/IP and 802.11 network information.
Font Information	Name, type, and size of installed fonts.
Bar Code Information	Name and type of installed bar code fonts.
Image Information	Name, type, and size of installed images.

Check the Printer Odometer

You can check the odometer from the printer web page to see the printhead usage and how the current values compare to the alert values. To check the printer odometer from the printer web page, the printer must be turned on and connected to your Wi-Fi or Ethernet network.

- 1** On your desktop PC, start a browser.
- 2** In the **Location** or **Address** bar, type the printer IP address and press **Enter**. The web page for the printer appears.
- 3** Click the **System Information** tab.

- 4 Click **Odometer**. The list of current odometer statistics appears.

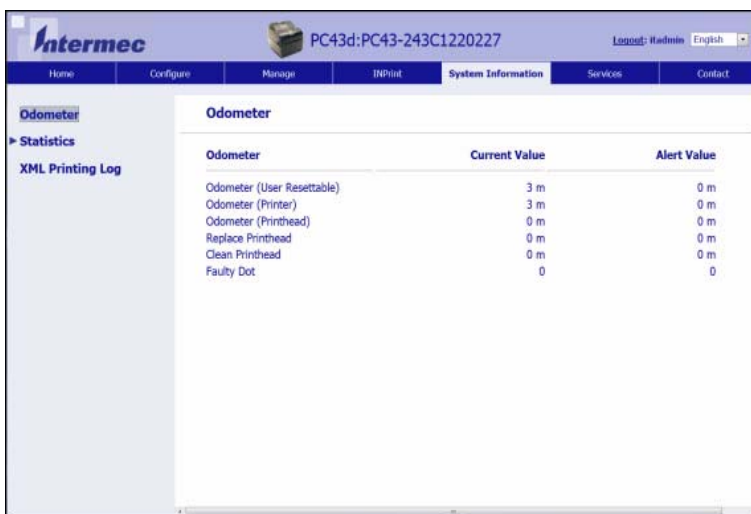

About Alerts

To help maintain the printer, you can configure the printer to send alert messages when certain conditions occur. For example, the printer can send a message when the odometer reaches a certain value, or if the printhead is lifted during printing.

There are three types of alerts:

- Error alerts
- Information alerts
- Warning alerts

You configure alert settings in the printer web page. Alert messages can be sent to an email address, an SNMP trap, or both. You can enable or disable each type of alert, set the number of times the alert is repeated, set the unit of measure that determines how often the alert is sent, and change the default text message for the alert.

Configure Alerts

This section explains how to configure alerts and alert messages. You configure alert settings from the printer web page.



Note: To configure the printer from its web page, the printer must be turned on and connected to your Wi-Fi or Ethernet network.

- 1 On your desktop PC, start a browser.
- 2 In the **Location** or **Address** bar, type the printer IP address and press **Enter**. The printer web page appears.
- 3 Click **Login** in the upper right corner of the screen. The Login page appears.
- 4 Type your **Username** and **Password** in the entry fields, and then click **Login**.
- 5 Click the **Configure** tab > **Alerts**.

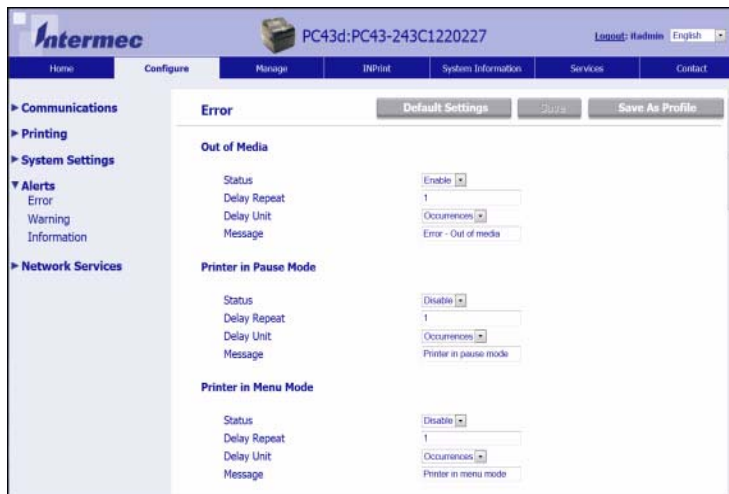

- 6 Click **Error** to configure error alerts.
Click **Warning** to configure warning alerts.
Click **Information** to configure information alerts.

- 7 Change alert settings as necessary. When you are finished, click **Save**.

To restore default settings for all alerts on the page, click **Default Settings**.

Maintenance and Error Alert Messages

Use these tables to understand and troubleshoot some common error alerts you may receive and how to fix them.

Maintenance and Error Alert Messages

Message	Description and Solution
Label Not Taken	Printing has been stopped because a label is obstructing the label taken sensor. Remove the label to resume printing.
Printhead Lifted	Lower the printhead.
Out of Ribbon	Load ribbon in the printer.
Out of Media	Load media in the printer.
Ribbon Installed	The printer is configured as a direct thermal printer and thermal transfer ribbon is installed. Remove the ribbon or configure the printer for thermal transfer media.
Printer in Pause Mode	A print job is paused from the front panel. Press the Print button to resume printing.
Printer in Menu Mode	A user entered a menu from the front panel. Press the Home button to return to the Ready screen.
Application Break	Fingerprint only. An application breaks uncontrolled.
Print Job Complete	A print job has been successfully completed.
Odometer (Printer)	The printer has reached a limit set in the Odometer (Printer) setting in Maintenance Alerts for the amount of media to print before being alerted.
Odometer (User Resettable)	The printer has reached a limit set in the Odometer (User Resettable) setting in Maintenance Alerts for the amount of media printed since the last reset.
Printhead Too Hot	The printhead is overheated and needs to cool down. Wait for printing to resume automatically.
Printhead Not Detected	The printer is not detecting the printhead. Check the printhead cable.

Maintenance and Error Alert Messages (Continued)

Message	Description and Solution
Faulty Dot	The printhead has reached the number of faulty dots set in the Faulty Dots setting in Maintenance Alerts. You may need to replace the printhead.
Replace Printhead	The printer has reached a limit set in the Replace Printhead setting in Maintenance Alerts for the amount of media to print before replacing the printhead. Replace the printhead.
Clean Printhead	The printer has reached a limit set in the Clean Printhead setting in Maintenance Alerts for the amount of media to print before cleaning the printhead. Clean the printhead.
No RFID Tag Found	The printer cannot find an RFID tag. You need to disable RFID on the printer.
RFID Not Installed	You are attempting to write to a tag, but the printer does not support RFID. You must install the RFID module in the printer to be able to write to RFID tags.
Upgrading Firmware	The printer is going to start upgrading the firmware. Do not try to send anything to the printer.
Printer is Rebooting	The printer is going to restart. Wait until the printer is ready before attempting to communicate with it.
Started	The printer is in the process of starting up.

Problems and Possible Solutions

Use this table to understand and troubleshoot some common problems you may encounter.

Problems and Possible Solutions

Problem	Possible Solution
The printer does not feed media correctly.	Remove the media from the media compartment and reinstall the media.
The printer is connected to a serial port on my PC, but the printer is not working.	Try these possible solutions: <ul style="list-style-type: none"> • Make sure the serial port settings are configured correctly. • If you have the Intermec Windows driver for an RS-232 printer installed on your PC, uninstall the driver.
The printer is connected to my PC using a virtual COM port, and printing stops. But, there are no errors to indicate that something is wrong.	Make sure that bidirectional support is disabled. From the printer properties dialog box, click the Ports tab, and then clear the Enable bidirectional support check box.
The printout is weak.	Try these possible solutions in order: <ul style="list-style-type: none"> • Make sure that your media setting is appropriate for the type of media you are using. • The contrast may be too low. Increase the contrast. • Replace the printhead.
There are weak spots on the printout.	Try these possible solutions in order: <ul style="list-style-type: none"> • There may be foreign particles on the media. Clean or replace the media. • Make sure that your media and ribbon are compatible. • Make sure that you are using high quality media and ribbon. • The contrast may be too low. Increase the contrast.

Problems and Possible Solutions (Continued)

Problem	Possible Solution
The printout is dark or there is excessive bleeding on the media.	<p>Try these possible solutions in order:</p> <ul style="list-style-type: none"> • Make sure your media setting is appropriate for the type of media you are using. • The contrast may be too high. Decrease the contrast. • The printhead voltage may be incorrect or the energy control may be faulty. For help, contact your Intermec representative.
There are dark lines along the media path.	The printhead may be dirty. Clean the printhead.
There are white vertical lines on the printout.	<p>Try these possible solutions in order:</p> <ul style="list-style-type: none"> • The printhead may be dirty. Clean the printhead. • There may be missing dots on the printhead. Replace the printhead. • The ribbon may not be installed correctly.
Part of a dotted line is missing.	<p>Try these possible solutions in order:</p> <ul style="list-style-type: none"> • The printhead may be failing. Replace the printhead. • The strobe signal may be failing. For help, contact your Intermec service representative.
The inner edge of the printout is missing.	<p>Try these possible solutions in order:</p> <ul style="list-style-type: none"> • The media may not be properly installed or aligned. Reload the media. • The media margin or X-start parameter may be set too low. Increase the setting.
The content on my printout is compressed.	The print speed may be too high. Lower the print speed.
Nothing shows up on my thermal transfer printout.	The ink-coated side of the ribbon may not be facing the media. Reload the ribbon.

Problems and Possible Solutions (Continued)

Problem	Possible Solution
When I feed or print a label, the ribbon is not taken up. Instead, it spills out the front of the printer.	Try these possible solutions in order: <ul style="list-style-type: none">• Make sure the ribbon is loaded correctly and that you are using the correct type of ribbon for the printer.• If you are using ribbon with a notchless core, you must use the ribbon core adapter for the ribbon feed to work properly.
The ribbon breaks.	Try these possible solutions in order: <ul style="list-style-type: none">• Make sure your media setting is appropriate for the type of media you are using.• Make sure that the ribbon is fitted correctly. Reload the ribbon.• The energy control may be faulty. For help, contact your Intermec Service representative.
The Ethernet or wireless network connection is not working correctly.	Try these possible solutions: <ul style="list-style-type: none">• Make sure your network cable is securely connected to your printer and a straight “pin-to-pin” cable, not a “crossover” cable.• Make sure your PC is correctly configured for and connected to your network.• Make sure your printer is correctly configured for your network.
I cannot connect to the printer web page.	If you are connecting your printer with a crossover network cable, you may need to disable the web browser’s proxy settings on your computer to access the printer web page.
The printer has RFID media loaded, but it is not writing to the tags.	After you load RFID media, restart the printer to let the printer identify the RFID media type or run the RFID calibration wizard.

Problems and Possible Solutions (Continued)

Problem	Possible Solution
The RFID module is installed in the printer, but “RFID” does not appear in the menu.	The printer is not communicating properly with the RFID hardware. For help, contact your local Intermec representative.
None of the RFID commands work.	RFID is disabled. Enable RFID from the web page or the Main Menu. Go to Settings (Main Menu) or Configure tab (web page) > System Settings > Manage I/O .
Printing on regular media (not RFID) is slow and halted in between labels.	RFID is enabled. Disable RFID from the web page or the Main Menu.
I am using an application to write to RFID tags and the printer is printing “VOID” labels.	<p>Try these possible solutions:</p> <ul style="list-style-type: none"> • The printer may not recognize the RFID media type. Restart the printer or run the media or RFID calibration wizard. • You may need to modify the Tag Position parameter. • You may need to adjust the output power (field strength) to the antenna.
I receive this message “No RFID tag found.”	<p>Try these possible solutions:</p> <ul style="list-style-type: none"> • Make sure you are using RFID media. • You may need to modify the Tag Position parameter. • The tag may be broken. Try printing on a different label.
When I send a TAGREAD or TAGWRITE command, I get this error message: “Tag format error.”	<p>The TAGFORMAT defined for the operation determines the number of required parameters. You may need to modify the TAGFORMAT. For help, see the Intermec Fingerprint Command Reference Manual or the IPL Command Reference Manual. For more information, see the EPC Tag Data Standard (v1.1, revision 1.27) available from the EPCglobal website at www.epcglobalinc.org.</p>



Problems and Possible Solutions (Continued)



Problem	Possible Solution
My icon printer uses the ZSim printer language and prints configuration labels every time I turn the power on.	Icon printers running ZSimprint configuration labels on startup by default. To prevent this, use Notepad to create a .txt file named “STLABPD41nPM43.txt”. In the file, type “0”. Copy the file to the /home/user directory on the printer.
My printer does not communicate with my desktop PC when they are connected with the USB-to-parallel adapter cable.	Windows may not have installed the driver. Follow these steps: <ol style="list-style-type: none"><li data-bbox="744 509 1210 568">1 Connect the adapter cable to the printer but not to the PC.<li data-bbox="744 568 1210 626">2 Turn the printer on and wait until the startup process is complete.<li data-bbox="744 626 1210 685">3 Turn the printer off, and then turn the printer on.<li data-bbox="744 685 1210 743">4 Connect the adapter cable to the PC. Windows auto-detects the printer and installs the driver.<li data-bbox="744 743 1210 802">5 After the driver is installed, run a test print.

Restore Defaults by Using a Hardware-Based Reset

You can restore the printer defaults by performing a hardware-based reset.

- 1 Turn the printer off.
- 2 Pull one or both of the printer latches forward and lift the printer lid.
- 3 Turn the printer on.

- 4 For an icon printer, watch the icon panel. When the bottom row of icons turns off, press and hold , and release  when the  icon begins flashing.

For an LCD printer, watch the startup progress bar. When the bar is halfway across the screen, press and hold , and release  when the first screen of the Startup Wizard appears.

- 5 Close the printer lid. The defaults are restored. For an LCD printer, follow the instructions in the Startup Wizard.

Restore Defaults from the Printer Web Page

If the printer is connected to an Ethernet or wireless network, you can restore default settings from the printer web page.

- 1 On your desktop PC, start a web browser.
- 2 In the address field, type the printer IP address and then press **Enter**. The printer web page appears.

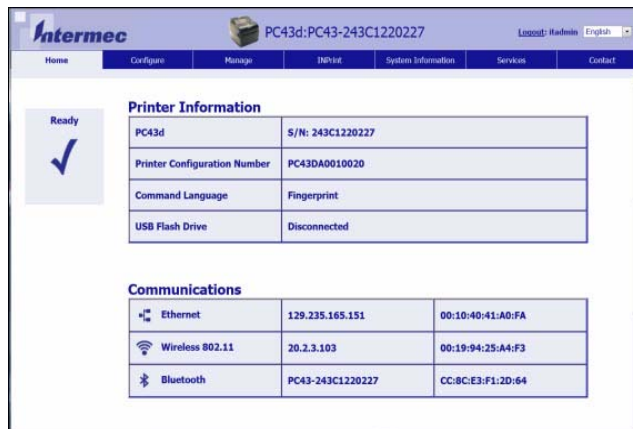

- 3 Click **Login** in the upper right corner of the screen. The Login page appears.
- 4 Type your **Username** and **Password** in the entry fields and then click **Login**. The default username is `itadmin` and the default password is `pass`.

5 Click the **Services** tab > **Restore Defaults**.

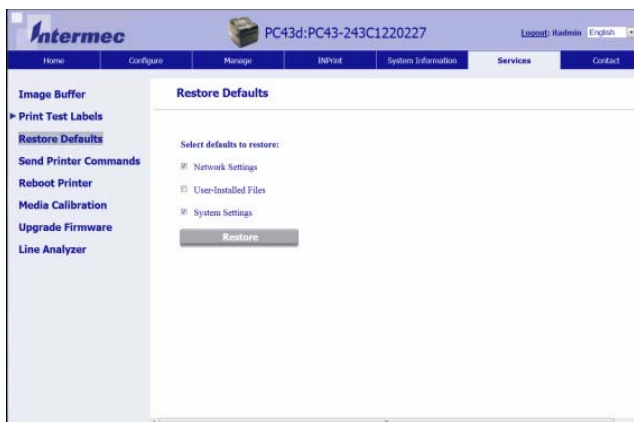

6 Select the settings you want to restore:





- Check the **Network settings** check box to restore defaults for all network connections, such as IP address and network name.
- Check the **User files** check box to erase all files you uploaded to the printer memory.
- Check the **System Settings** check box to restore defaults for system settings, such as media width or maintenance alerts.

7 Click **Restore Defaults**.

8 Click **Yes** to continue. The printer restarts and the settings you selected are restored to default values.

Restore Defaults from the Main Menu

This topic explains how to reset printer settings to their default values from the Main Menu. You can choose to restore default network settings, keep or delete user-installed files, and to restore all system settings like media type or serial port settings.

- 1 From the Ready screen, press . The Main Menu appears.
- 2 Select **Tools > Restore Defaults**. The Restore Defaults menu appears with all items in the list selected by default. If you continue without changing anything, the current network and system settings will be restored to default values, and any files or programs you uploaded to the printer will be erased from the printer memory.
- 3 To restore all default settings, continue with the next step. You can also change the settings that are restored as follows:
 - To keep the current network settings, clear the **Network settings** check box.
 - To keep all applications, fonts, and other files you have installed on the printer, clear the **User files** check box.
 - To keep all current system settings, clear the **System Settings** check box.
- 4 Select  and press .
- 5 To continue, press . The default settings are restored and the printer restarts. When the printer finishes starting up, the Setup Wizard begins. Follow the instructions to complete the Wizard.

To return to the Main Menu without restoring any defaults, select **No**. To return to the Restore Defaults list without restoring any defaults, select **Cancel**.

How to Upgrade the Printer Firmware

You should check for periodic updates to the printer firmware. Updated firmware can include bug fixes or additional features that you might find useful. The latest version of the firmware is available from the PC23 or PC43 printer Downloads page on www.intermec.com.

You can upgrade the printer firmware using:

- the printer web page.
- a USB storage device.
- the USB menu.
- PrintSet 5. For more information, see the PrintSet 5 online help.



Note: After you upgrade the printer firmware, Intermec recommends that you restore the default settings and calibrate the media sensors.

Download the Printer Firmware Update

Before you can upgrade the printer firmware, you need to download the upgrade file from the Intermec website.

- 1 Go to the Intermec website at www.intermec.com.
- 2 Click **Support** > **Downloads**.
- 3 Use **Product Category**, **Product Family**, and **Product** to select the PC23 or PC43PD43 or PD43c.
- 4 Click **Submit**. The latest software appears on the page.
- 5 Download the latest firmware version to your PC.

Upgrade Firmware from the Printer Web Page

You can upgrade the printer firmware from the printer web page. To configure the printer from the web page, the printer must be turned on and connected to your Wi-Fi or Ethernet network.

- 1 On your PC, open a browser.
- 2 In the **Location** or **Address** field, type the printer IP address and press **Enter**. The printer web page appears.

- 3** Click **Login** in the upper right corner of the screen. The Login page appears.
- 4** Type your **Username** and **Password** in the text fields and click **Login**.
- 5** Click the **Services** tab and then select **Firmware Upgrade**. The Firmware Upgrade screen appears, showing the current firmware version.
- 6** Click **Browse** to locate the upgrade file, select it, and then click **Open**.
- 7** Click **Upgrade**. The printer web page shows that it is upgrading firmware on your printer.

Upgrade Firmware from a USB Storage Device

You can upgrade the printer firmware from a USB storage device.



Note: For best results, Intermec recommends using a USB storage device that contains no other files.

- 1** Make sure the USB storage device has a single partition and is formatted as FAT16 or FAT32.
- 2** Download the printer firmware from the Intermec website.
- 3** Copy the firmware upgrade file (typically in .bin format) to the root of a USB storage device.
- 4** Insert the USB storage device into one of the USB host ports.
- 5** Restart the printer. The upgrade file is loaded into the printer memory. This may take several minutes.



For the LCD printer, after the upgrade file is loaded, the printer restarts and the Ready screen appears. The printer is ready to use.

For the icon printer, as the upgrade file is loaded, all icons in the icon panel turn on and then turn off, except for the Maintenance icon. After the upgrade file is loaded, the printer restarts and the Ready-to-Work indicator turns on:

- If the Ready-to-Work indicator turns on and stays on, the upgrade process is finished and the printer is ready to use.
- If the Ready-to-Work indicator is flashing, you need to restart the printer once again to complete the upgrade.
- If the Ready-to-Work indicator is off, there may be a condition that is preventing the printer from restarting. For example, the printer lid may not be fully closed.

Upgrade Firmware from the USB Menu

If you have an LCD printer, you can upgrade the printer firmware through the USB menu. This procedure is different from upgrading firmware from a USB storage device without going through the USB menu.

- 1** Make sure the USB storage device has a single partition and is formatted as FAT16 or FAT32.
- 2** Download the printer firmware from the Intermec website.
- 3** On your USB storage device, create a /firmware directory.
- 4** Copy the firmware upgrade file (typically .bin format) to the /firmware directory on the USB storage device.
- 5** Insert the USB storage device into the printer USB host port. The USB Menu appears.
- 6** In the USB Menu list, select **Upgrade Firmware**.
- 7** In the Upgrade Firmware list, select the firmware upgrade file and press . An “Upgrade Firmware?” message appears.
- 8** Press  to start the upgrade. When the upgrade is complete, the printer restarts and the Ready screen appears.

6

Maintain the Printer

This section explains how to perform basic maintenance on the PC23 and PC43 printers.

Clean the Printhead

Cleaning the printhead on a regular basis is important for the life of the printhead and for the print quality. You should clean the printhead each time you replace the media. Follow this procedure to clean the printhead using the cleaning card. If you need to clean additional residue from the platen roller or tear bar, use a cotton swab moistened with isopropyl alcohol.



Caution: Never use hard or sharp tools to peel away stuck labels or other material. The printhead is delicate and can easily be damaged.

- 1 Turn the printer off and disconnect the printer from power.
- 2 Open the printer and remove the media and ribbon (if installed).
- 3 Insert most of the cleaning card under the printhead, and then lower the printhead.
- 4 Pull out the cleaning card and raise the printhead.
- 5 Wait for approximately 30 seconds to allow the cleaning fluid to dissolve the residue.
- 6 Repeat Steps 3 through 5 if necessary.
- 7 If necessary, clean residue from the platen roller or tear bar with a cotton swab moistened with isopropyl alcohol.
- 8 Once the parts are dry, replace the media (and ribbon) in the printer.
- 9 Close the printer, reconnect power, and turn on the printer.

Replace the Printhead

You need to replace the printhead periodically when it wears out due to the rapid heating and cooling process used during printing. How often you need to replace the printhead depends on factors such as what type of images you print, the type of media or ribbon you use, the amount of energy to the printhead, the print speed, and the ambient temperature of the room you print in. The firmware detects the new printhead when you restart the printer.

- 1** Turn off the printer and disconnect the power cord.
- 2** Pull one or both of the printer latches toward the front of the printer and lift the printer lid.

For a thermal transfer printer, remove the ribbon.

- 3** Press the printhead latches apart until the printhead slides forward.

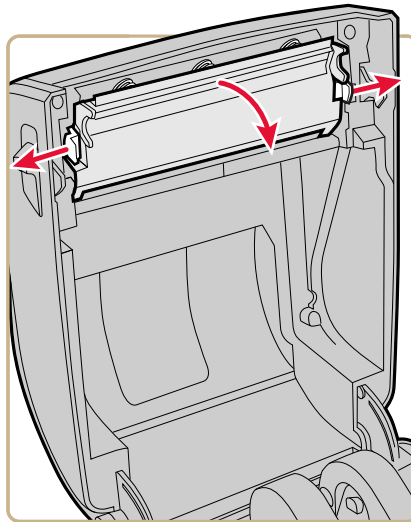

- 4 Carefully slide the printhead out of the mechanism. The printhead is still attached to the mechanism by a ribbon cable.

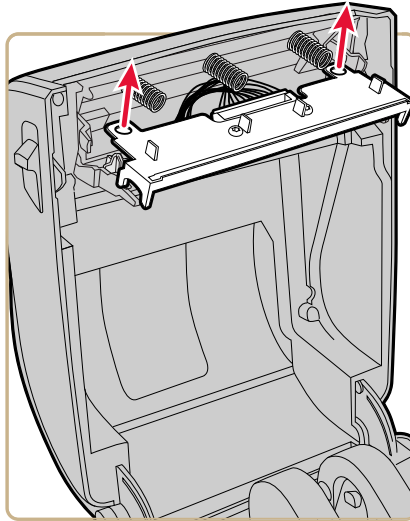

- 5 Disconnect the cable from the printhead and remove the printhead from the printer.

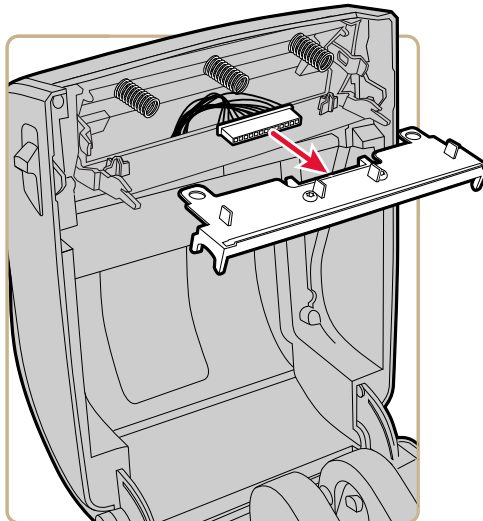



Warning: Do not touch the printhead surface area.

- 6** Connect the ribbon cable to the new printhead.
- 7** Slide the printhead into the holders in the print mechanism.
- 8** Press the printhead onto the locator pins in the mechanism.
- 9** Tilt the printhead up into the printer lid and press it into place. When the printhead is in the correct position, the printhead latches snap into place on the sides of the printhead.
- 10** For a thermal transfer printer, install the ribbon.
- 11** Close the printer lid until it snaps shut.
- 12** Print a test label.

Clean the Platen Roller

Follow this procedure to remove, clean, and replace the platen roller as part of standard maintenance for the printer. Intermec recommends that you check the platen roller for debris and clean it each time you replace media.

- 1** Turn the printer off and disconnect the power cord.
- 2** Pull one or both of the printer latches toward the front of the printer and lift the printer lid.
- 3** Remove the installed media.

- 4** Press the roller latches apart and tilt them up.

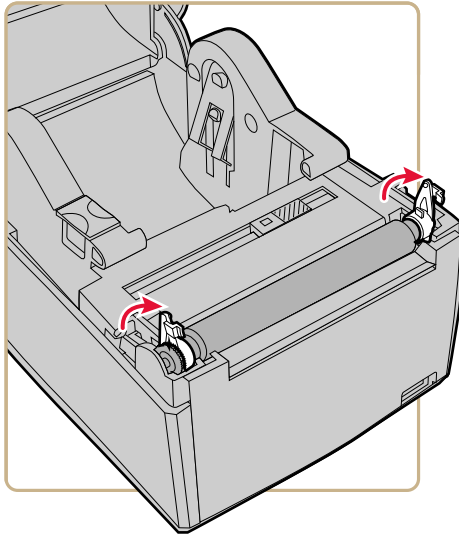

- 5** Pull the latches up to remove the platen roller from the printer.

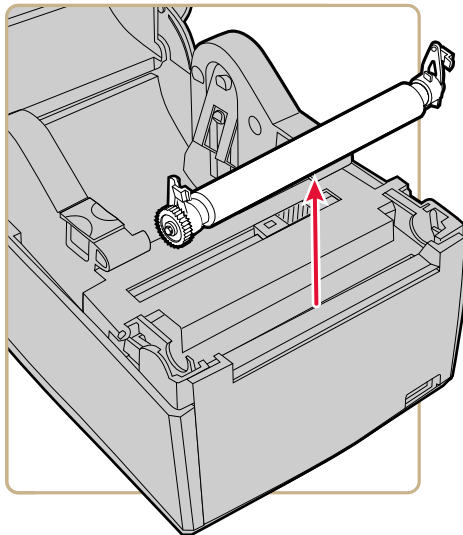

- 6** Remove any adhesive residue from the roller with a cotton swab moistened with isopropyl alcohol.
- 7** Reverse Steps 4 and 5 to install the roller.

- 8 Press the latches into the printer until they snap into place.
- 9 Replace the media in the printer.
- 10 Close the printer lid until it snaps shut.

Clean the Exterior of the Printer

Make sure to keep the exterior of the printer clean. Maintaining a clean exterior will reduce the risk of dust or foreign particles reaching the inside of the printer and affecting printer functionality.

Use a soft cloth, possibly moistened with water or a mild detergent, when cleaning the printer exterior.

Make sure to keep the surface surrounding the printer clean as well.

Recommended Cleaners

Intermec has tested and recommends these cleaning products for compatibility with the exterior surfaces of the PC23 and PC43 printers.



Note: Do not use products containing ethylene glycol to clean the exterior of the PC43t.

Recommended Cleaners

Manufacturer	Product	Use On These Printers
Homax	Goo Gone	All
Johnson	Virex TB	All
Metrex	Cavi Wipes	All
Multiple suppliers	70% isopropyl alcohol Ammonium chloride 10% Ethylene glycol Screen Clearer Sodium Hypochlorite 6%	All. Do not use ethylene glycol to clean the exterior of the PC43t.
Orange-Sol	Multi-Use Citrus	All
PDI	SANI-CLOTH HB SANI-CLOTH PLUS SUPER SANI-CLOTH	All
PDI and others	Alcohol Prep Pads	All

Recommended Cleaners (Continued)

Manufacturer	Product	Use On These Printers
Quest Chemical Corporation	Grime Buster	All
Spartan	Super HDQL 10	All
Surgipath	Cloro-Wipe Towelette	All
Techspray Renewal	Eco-Shower	All
Veridien	Viraguard®	All
Vernacare	Tuffiewipes	All

A

Specifications

This appendix contains specifications for the PC23 and PC43 printers.

Printer Specifications

PC23d Physical Specifications

Dimensions:	17.7 cm x 12.5 cm x 21.5 cm (6.97 in x 4.92 in x 8.46 in)
Weight:	1.45 kg (3.20 lbs)
Power Supply Requirements:	100–240 VAC, 50–60 Hz, 60 W
Operating Temperature:	5 °C to 40 °C (41 °F to 104 °F)
Storage Temperature:	-40 °C to 60 °C (-40 °F to 140 °F)
Relative Humidity:	20 to 80% non-condensing

PC23d Print Speed, Resolution, and General Media Specifications

Print Mode:	Direct thermal
Print Speed (variable):	203 dpi: 50 to 200 mm/sec (2 to 8 ips) 300 dpi: 50 to 150 mm/sec (2 to 6 ips)
Print Resolution:	203 dpi: 8 dots/mm 300 dpi: 11.8 dots/mm
Print Width:	203 dpi: 54 mm (2.1 in) max 300 dpi: 56 mm (2.2 in) max
Media Width:	15 to 60 mm (0.59 to 2.36 in)
Label Roll Diameter (maximum):	127 mm (5 in)
Label Length (minimum):	6.35 mm (.25 in)
Gap Length Between Labels:	2 to 10 mm (0.08 to 0.39 in)
Black Mark Length	3 to 10 mm (0.12 to 0.39 in) centered between tickets, 15% maximum reflectance
Media Thickness:	76.2 to 203 µm (3 to 8 mil), flexible wristbands up to 10 mils (maximum)
Media Density:	60 to 181 g/m ²
Liner Opacity (maximum):	76% (TAPPI T425)
Label Stop Sensor	Adjustable from left media edge to 4.5 mm right of center on LCD printers (fixed at center on Icon printers)

PC43d Physical Specifications

Dimensions:	16.8 cm x 18.0 cm x 21.5 cm (6.61 in x 7.09 in x 8.46 in)
Weight:	1.72 kg (3.80 lbs)
Power Supply Requirements:	100–240 VAC, 50–60 Hz, 60 W
Operating Temperature:	5 °C to 40 °C (41 °F to 104 °F)
Storage Temperature:	-40 °C to 60 °C (-40 °F to 140 °F)
Relative Humidity:	20 to 80% non-condensing

PC43d Print Speed, Resolution, and General Media Specifications

Print Mode:	Direct thermal
Print Speed (variable):	203 dpi: 50 to 200 mm/sec (2 to 8 ips) 300 dpi: 50 to 150 mm/sec (2 to 6 ips)
Print Speed (on battery power):	203 dpi: 50 to 150 mm/sec (2 to 6 ips) 300 dpi: 50 to 100 mm/sec (2 to 4 ips)
Print Resolution:	203 dpi: 8 dots/mm 300 dpi: 11.8 dots/mm
Print Width:	203 dpi: 104 mm (4.09 in) max 300 dpi: 106 mm (4.17 in) max
Media Width:	19.05 to 118 mm (0.75 to 4.65 in)
Label Roll Diameter (maximum):	127 mm (5 in)
Label Length (minimum):	6.35 mm (0.25 in)
Gap Length Between Labels:	2 to 10 mm (0.08 to 0.39 in)
Black Mark Length	3 to 10 mm (0.12 to 0.39 in) centered between tickets, 15% maximum reflectance
Media Thickness:	76.2 to 203 µm (3 to 8 mil)
Media Density:	60 to 181 g/m ²
Liner Opacity (maximum):	76% (TAPPI T425)
Label Stop Sensor	Adjustable from left media edge to 4.5 mm right of center on LCD printers (fixed at center on Icon printers)

PC43t Physical Specifications

Dimensions:	18.2 cm x 21.1 cm x 28.1 cm (7.17 in x 8.31 in x 11.06 in)
Weight:	2.70 kg (5.95 lbs)
Power Supply Requirements:	100–240 VAC, 50–60 Hz, 60 W
Operating Temperature:	5 °C to 40 °C (41 °F to 104 °F)
Storage Temperature:	-40 °C to 60 °C (-40 °F to 140 °F)
Relative Humidity:	20 to 80% non-condensing

PC43t Print Speed, Resolution, and General Media Specifications

Print Mode:	Thermal transfer or direct thermal
Print Speed (variable):	203 dpi: 50 to 200 mm/sec (2 to 8 ips) 300 dpi: 50 to 150 mm/sec (2 to 6 ips)
Print Resolution:	203 dpi: 8 dots/mm 300 dpi: 11.8 dots/mm
Print Width:	203 dpi: 104 mm (4.09 in) max 300 dpi: 106 mm (4.17 in) max
Media Width:	19.05 to 118 mm (0.75 to 4.65 in)
Label Roll Diameter (maximum):	127 mm (5 in)
Label Length (minimum):	6.35 mm (.25 in)
Gap Length Between Labels:	2 to 10 mm (0.08 to 0.39 in)
Black Mark Length	3 to 10 mm (0.12 to 0.39 in) centered between tickets, 15% maximum reflectance
Media Thickness:	76.2 to 203 µm (3 to 8 mil)
Media Density:	60 to 181 g/m ²
Liner Opacity (maximum):	76% (TAPPI T425)
Ribbon Width	25.4 to 110 mm (1 to 4.33 in)
Ribbon Roll Diameter (maximum)	68 mm (2.68 in)
Ribbon Core (I.D.)	12.7 mm or 25.4 mm (0.5 or 1 in)
Ribbon Core Length	110 mm (4.33 in) notched
Ribbon Wound Ink Side	Out, only
Label Stop Sensor	Adjustable from left media edge to 4.5 mm right of center on LCD printers (fixed at center on Icon printers)

Memory

- 128 MB flash
- 128 MB SDRAM
- (optional) USB memory device, up to 32 GB

Supported Command Languages

- Fingerprint
- Direct Protocol
- Intermec Printer Language (IPL)
- ESim
- ZSim
- DSim

Media Sensors

- Label stop sensor
- Cover open
- Label taken (on cutter and label dispenser accessories)

Network Services

- FTP
- HTTP Server
- SNMP
- Line Printer Remote Protocol (lpr)
- Telnet
- DHCP
- Ping
- IPSEC/IKEv2 over IPv6
- SSH

Universal Font Scaling Technology and Standard Latin Fonts

- Monotype Century Schoolbook
- CG Times
- CG Times Bold
- Letter Gothic
- Andale Mono (WGL4)
- Andale Mono Bold (WGL4)
- Univers 55
- Univers Bold 65
- Univers Condensed Bold
- Univers Extra Condensed
- OCR-A
- OCR-B

Supported Font Types

- TrueType
- OpenType
- Bitmap

Localization Fonts

- Simplified Chinese (optional)
- Traditional Chinese (optional)
- Cyrillic
- Korean (Optional)
- Latin
- Greek
- Turkish
- Hebrew
- Arabic
- Baltic
- Baltic Rim
- Vietnamese
- Thai

Supported Graphic File Types

Supports 1-bit color depth (black and white) only:

- PCX
- PNG
- GIF
- BMP

Drivers

- Support for Microsoft Windows XP, Vista, Windows 7, Server 2003, and Server 2008
- Supports 32-bit and 64-bit editions

Supported Bar Code Symbologies

1D bar code symbologies:

- Codabar
- Code 11
- Code 39:
 - Code 39 full ASCII
 - Code 39 with checksum
- Code 93
- Code 128:
 - Code 128 Subset A
 - Code 128 Subset B
 - Code 128 Subset C
 - Code 128 UCC
- DUN-14/16
- EAN:
 - EAN-8
 - EAN-13
 - EAN 128

Appendix A – Specifications

- EAN 128 subset A
- EAN 128 Subset B
- EAN 128 Subset C
- HIBC 39
- HIBC 128
- Industrial 2 of 5:
 - Industrial 2 of 5 with checksum
- Interleaved 2 of 5:
 - Interleaved 2 of 5 with checksum
 - Interleaved 2 of 5 IATA
- ISBT-128
- Matrix 2 of 5
- Straight 2 of 5
- UPC:
 - UPC-A
 - UPC-D1
 - UPC-D2
 - UPC-D3
 - UPC-D4
 - UPC-D5
 - UPC-E
 - UPC Shipping container Code

Add-on bar code symbologies:

- Add-on 2
- Add-on 5
- UPC-5 digits Add-on code

2D bar code symbologies:

- Aztec
- Code 16K
- Code 49

- Data Matrix
- Dot Code
- Grid Matrix
- GS1 DataBar (previously called RSS-14):
 - GS1 DataBar Expanded
 - GS1 DataBar Expanded Stacked
 - GS1 DataBar Limited
 - GS1 DataBar Stacked
 - GS1 DataBar Stacked Omnidirectional
 - GS1 DataBar Truncated
- MaxiCode
- MicroPDF417
- MSI (modified Plessey)
- PDF417
- Planet
- Plessey
- Postnet
- QR Code
- USPS 4-State Customer Bar Code

Composite bar code symbologies:

- EAN-8 Composite (CC-A, CC-B)
- EAN-13 Composite (CC-A, CC-B)
- GS1 Composite (previously called EAN.UCC Composite)
- UPC-A Composite (CC-A, CC-B)
- UPC-E Composite (CC-A, CC-B)

Test Labels

This section describes test label information. A typical test label looks like this:

Resident Fonts	
Andale Mono	123456789
Andale Mono Bold	123456789
CG Times	123456789
CG Times Bold	123456789
Century Schoolbook Roman	123456789
IPLFONT0	123456789
IPLFONT1	123456789
IPLFONT2	123456789
IPLFONT7	123456789
Letter Gothic	123456789
OCR A	123456789
OCR B	123456789
Univers	123456789
Univers Bold	123456789
Univers Condensed Bold	123456789
Univers Extra Condensed	123456789
Downloaded Fonts	
None	

Sample Configuration Label for Fonts

Resource Labels

Label	Description
Applications	All Intermec utility programs and user-installed applications.
Fonts	Resident and user-installed fonts.
Bar Codes(Barcodes)	Resident bar codes (partial label shown).
Images	All images, including resident and user-installed files.

Printer Information Labels

Label	Description
Installed Hardware	<p>List of hardware modules in the printer, including:</p> <ul style="list-style-type: none"> • Main logic board configuration number • Wireless 802.11 MAC address • Ethernet • Serial Port • USB Device • USB Host • Bluetooth • Thermal Printhead • Front Panel • Ribbon • Power Supply Unit
Print Statistics	<p>Number of labels printed, current odometer value, and total distance printed.</p>
System Information	<p>General product information, including:</p> <ul style="list-style-type: none"> • Firmware version • Product name, configuration number, serial number, system name, and command language • Printhead resolution • Mean printhead resistance • Total flash memory and available flash memory • Total RAM and free RAM

Printer Settings Labels

Label	Description
Media and Printing	Current settings for media handling, including: <ul style="list-style-type: none">• Media width, length, and X-margin• Selected media type• Printing method (TTR or DT) and speed• Start Adjust and Stop Adjust values
Ethernet Settings	<ul style="list-style-type: none">• MAC Address• Primary and secondary DNS servers• IPv4 settings: IP assignment method, IP address, subnet mask, default router, DHCP response type• IPv6 settings: IP assignment method, IP address
Serial Port Settings	<ul style="list-style-type: none">• Baud rate• Data bits• Parity• Stop bits• Flow control: Hardware, ENQ/ACK, XON/XOFF To, XON/XOFF From• New Line character
Bluetooth Settings	<ul style="list-style-type: none">• Bluetooth MAC address (human-readable and bar code formats)• Security status• Device name and discovery state• Passkey• Reserve• ScanNGo bar code

Printer Settings Labels (Continued)

Label	Description
Wi-Fi General	<ul style="list-style-type: none"> • IP address and assignment method • Subnet mask • Default router • DHCP Response • IPv6 address and assignment method • 802.11 MAC address • Network name (SSID) and type • Roaming state • Power mode • Channel • Hidden SSID state • Country string • Access point MAC address • RSSI
Wi-Fi Security	<ul style="list-style-type: none"> • Security Type • Association • PreShared Key • Network Key Index • Network Key 1, 2, 3, 4 • User Name • Password • Anonymous Name • Inner Authentication • CA Certificate • Client Certificate • Client Key • Server Common Name 1 and 2 • Validate Certificate • PAC • Acquire PAC • Fast Roaming (CCKM) • Supplicant State

Print Quality Labels





Note: Although you can print test labels on any size media, the labels are designed to be printed on 10.16 cm x 15.24 cm (4 in x 6 in) media.

Print Quality Labels

Label	Description
Chess	 A rectangular label with a dark gray, textured background. At the bottom, there is a white area containing the following text: Mean Printhead Resistance: 900 Ohm Media: 604 dots Print Speed: 100 mm/sec Part Number: Serial Number:
Diamond	 A rectangular label with a white background featuring a repeating diamond or cross-hatch pattern. At the bottom, there is a white area containing the following text: Mean Printhead Resistance: 900 Ohm Media: 604 dots Print Speed: 100 mm/sec Part Number: Serial Number:

Print Quality Labels (Continued)

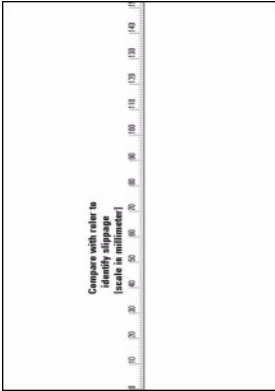
Label	Description
Pitch	 <p>Mass Printed Resistance: 500 Ohm Width: 104 dots Print Speed: 100 inches/sec Part Number: Serial Number:</p>
Pyramid	 <p>Mass Printed Resistance: 500 Ohm Width: 104 dots Print Speed: 100 inches/sec Part Number: Serial Number:</p>
Ruler	 <p>Compare with ruler to identify mispage (white misprints)</p>

Print Quality Labels (Continued)

	Description
Bar Code (Barcode)	
Wrinkle	

B

Default Settings

This appendix contains all of the default settings for the printer.

Default Configuration

Use this appendix to view the default settings on the printer. The following tables list the default settings for the printers. If you restore the printer to factory default settings, it will use the values listed here. The order of the settings reflects the organization of the printer web page and Main Menu.

Bluetooth Settings

This section describes Bluetooth settings for the printer. To view these settings:

- From the printer Main Menu, select **Settings > Communications > Bluetooth**.
- From the printer web page, click the **Configure** tab, **Communications > Bluetooth**.

Bluetooth Settings

Setting	Description	Default
Security	Selects the level of security that is used when pairing devices to the printer. If you select Authentication , you must enter a passkey. If you select Auth + Encrypt , you must enter a passkey and traffic is encrypted.	Disable
Device Name	Sets the name that identifies the printer in the Bluetooth network. Maximum length is 16 characters.	Printer model number and serial number. For example, PC43-0000000411.
Discover	Determines if other Bluetooth devices can detect the printer.	Enable
Passkey	Sets the passkey that is used when pairing Bluetooth devices to the printer. Range is 1 to 16 characters (case-sensitive).	1234

Bluetooth Settings (Continued)

Setting	Description	Default
Reserve	Determines if the printer is exclusively reserved for one Bluetooth device. The first Bluetooth device that connects with the printer locks out any other connection attempts.	Disable

Display and Audio Settings

This section describes display and audio settings for the printer. To view these settings:

- From the printer Main Menu, select **Settings > System Settings > Display or Audio**.
- From the printer web page, click the **Configure** tab, **System Settings > Display or Audio**.

Display and Audio Settings

Setting	Description	Default
Brightness	Selects the brightness of the printer screen.	Medium
Idle Information	Selects the information that appears on the printer screen when it is in Idle mode.	IPv4 address
Time Format	Selects the format used to display time on the printer.	24 Hour
Date Format	Selects the format used to display date on the printer.	dd/mm/yyyy
Menu Access	Determines if the Menu button on the printer web page is accessible.	Enable
PIN	Sets the password that allows access to the Menu button on the printer web page, if the Menu Access parameter is set to Enable With PIN. Range is 4 to 16 characters.	1234
Screen Timeout	Selects how long the printer screen stays on before the screen saver starts.	Disable
Feed Key Access	Determines if the Feed button on the printer keypad is enabled or disabled.	Enable
Volume	Sets the printer volume.	Off

Error, Information, and Warning Alert Settings

This section describes error, information, and warning alerts and settings.

To view these settings, from the printer web page, click the **Configure** tab, **Alerts > Error, Warning, or Information**.



Note: These alert settings cannot be configured from the printer Main Menu.

Alert settings apply to each of the error, information, or warning alerts and are configured individually by alert.

Alert Setting Descriptions

Setting	Description
Status	Determines if an alert is sent out for a specific printer event.
Delay Repeat	Sets how often the alert is sent out for a specific printer event. Range is 1 to 65535.
Delay Unit	Selects the unit of measure that determines how often the alert is sent out.
Message	Sets the message that is sent out with each alert for a specific printer event.

Error Alert Default Settings

Error Alert	Status	Delay Repeat	Delay Unit	Message
Out of Media	Enable	1	Occurrences	Error - Out of media
Out of Ribbon	Enable	1	Occurrences	Error - Out of ribbon
Printer in Pause Mode	Disable	1	Occurrences	Printer in pause mode
Printer in Menu Mode	Disable	1	Occurrences	Printer in menu mode
Application Break	Disable	1	Occurrences	Error - Application Break
RFID Not Installed	Disable	1	Occurrences	Error -RFID not installed

Error Alert Default Settings (Continued)

Error Alert	Status	Delay Repeat	Delay Unit	Message
Printhead Lifted	Enable	1	Occurrences	Error - Printhead lifted
Printhead Not Detected	Disable	1	Occurrences	Error - Printhead not detected

Information Alert Default Settings

Information Alert	Status	Delay Repeat	Delay Unit	Message
Print Job Complete	Disable	1	Occurrences	Print job complete
Started	Disable	1	Occurrences	Printer is started
Printer is rebooting	Disable	1	Occurrences	Printer is rebooting

Warning Alert Default Settings

Warning Alert	Status	Delay Repeat	Delay Unit	Message
Ribbon Installed	Disable	1	Occurrences	Warning - Ribbon installed
Upgrading Firmware	Disable	1	Occurrences	Warning - Upgrading firmware
Odometer (User Resetable)	Disable	1	Occurrences	Warning - Odometer (User resetable) has reached a preset value.
Odometer (Printer)	Disable	1	Occurrences	Warning - Odometer (Printer) has reached a preset value.
Replace Printhead	Disable	1	Occurrences	Warning - Replace printhead
Clean Printhead	Disable	1	Occurrences	Warning - Clean printhead
Faulty Dot	Disable	1	Occurrences	Warning - Faulty dot is detected

Error Alerts

Error alerts are sent when a condition occurs that prevents the printer from printing, such as running out of media. These alerts include:

- Out of Media
- Out of Ribbon
- Printer in Pause Mode
- Printer in Menu Mode
- Application Break
- RFID Not Installed
- Printhead Lifted
- Printhead Not Detected

Information Alerts

Information alerts are sent when a print job is started or completed, or when the printer is rebooting. These alerts include:

- Print Job Complete
- Printer is Rebooting
- Started (Sent when a print job has begun)

Warning Alerts

Warning alerts are sent when the printer may need attention shortly, such as when the printhead needs maintenance, or when the odometer has reached a present value. A warning alert is also sent when the printer firmware is being upgraded. Warning alerts include:

- Ribbon Installed (Sent when the printer is set for direct thermal printing but has ribbon installed for thermal transfer printing)
- Ribbon Low
- Upgrading Firmware
- Odometer (User Resettable)
- Odometer (Printer)
- Replace Printhead
- Clean Printhead

- Faulty Dot (Sent when a faulty dot is detected in the printhead, which can lead to lower print quality)

Ethernet Settings

This section describes the Ethernet IPv4 and IPv6 settings. To view these settings:

- From the printer Main Menu, select **Settings > Communications > Ethernet**.
- From the printer web page, click the **Configure** tab, **Communications > Ethernet**.

Ethernet Settings

Setting	Description	Default
(IPv4) IP Assignment Method	Specifies how the printer obtains an IP address.	DHCP
(IPv4) IP Address	Specifies the unique network-level address that is assigned to each device in a TCP/IP network (IPv4).	0.0.0.0
Subnet Mask	Specifies a number that defines the range of IP addresses that can be used in a TCP/IP network.	0.0.0.0
Default Router	Specifies the IP address of a router that is used when a device sends a packet to another subnet or to an unknown destination.	0.0.0.0
DHCP Response	Specifies if the printer receives DHCP responses by broadcast or unicast.	Broadcast
(IPv6) IP Assignment Method	Specifies how the printer obtains an IP address (for IPv6 networks).	Automatic
(IPv6) IP Address	Specifies the unique network-level address that is assigned to each device in a TCP/IP network (IPv6).	Automatic

General System Settings

This section describes general system settings. To view these settings:

- From the printer Main Menu, select **Settings > System Settings > General**.
- From the printer web page, click the **Configure** tab, **System Settings > General**.

General System Settings

Setting	Description	Default
System Name	Sets the network identification name (WINS name) of the printer.	Printer model number and serial number. For example, PC43-000000011.
System Location	Sets the location of the printer.	Empty string
System Contact	Sets the name of the printer administrator.	Empty string
XML Response Mode	Determines if the printer provides XML responses to printing requests (over Telnet and HTTP).	False
Display Language	(LCD printers only) Selects the language the printer uses to display text on the screen.	English
Display Language (Web Page)	Selects the language the printer uses to display text on the web page.	English
Keyboard Input	Selects the language of the external keyboard that is connected to the printer.	U.S./U.K.
Time	Sets the current time.	System time
AM/PM	Sets AM or PM.	AM
Date	Sets the current date.	System date
Sleep Timer	Selects the amount of time the printer waits before it goes to Sleep mode.	Disable
Command Language	Sets the printer command language. If changed, requires restart.	Fingerprint

General System Settings (Continued)

Setting	Description	Default
Alert Notification Method	Selects how you want the printer to notify you of printer alerts.	SNMP Trap + Email
Unit of Measure	Selects the unit of measure that is used to define several printing parameters.	Dots

Media Settings

This section describes media settings for the printer. To view these settings:

- From the printer Main Menu, select **Settings > Printing > Media**.
- From the printer web page, click the **Configure** tab, **Printing > Media**.



Note: If you are using an icon printer that is not on a network, you need to use PrintSet 5 through a USB connection to configure media settings.

Media Settings

Setting	Description	Default
Media Type	Selects the type of media that is loaded in the printer.	Media With Gaps
Print Method	Selects the method of printing that the printer is using.	Ribbon (TTR) for thermal transfer printers, or No Ribbon (DT) for direct thermal printers

Media Settings (Continued)

Setting	Description	Default
Media Margin (X)	Sets the width of the margin from the left edge of the label along the printhead to the edge of the printable area. Unit of measurement is defined in the Unit of Measurement parameter.	Variable

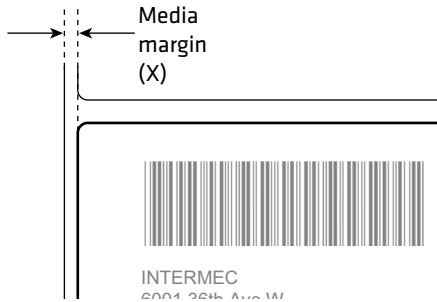

Media Width	Sets the width of the printable area measured from the media margin (X) across the printhead. Unit of measurement is defined in the Unit of Measure parameter.	Variable
-------------	--	----------

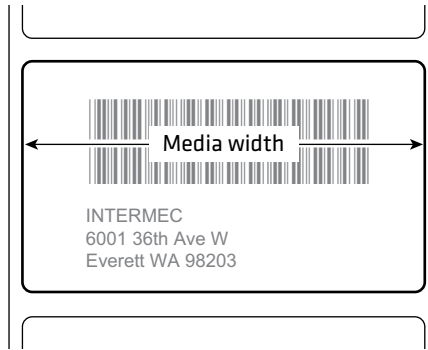

Media Settings (Continued)

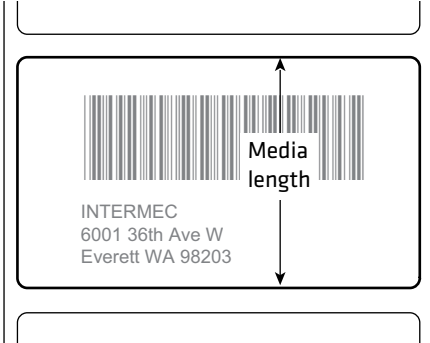
Setting	Description	Default
Media Length	Sets the length of the printable area measured from one edge of the label to the edge that is closest to the printhead. Unit of measurement is defined in the Unit of Measurement parameter.	Variable
		
Clip Default	Determines if the printer prints items outside the printable area of the label. When this is set to Off, the printer returns an error if any part of a bar code label cannot be printed because that part extends beyond the printable area. When this is set to On, the printer prints all bar code labels, but may also print unreadable, incomplete labels.	Off
Start Adjust	Sets the length of media the printer feeds (positive value) or retracts (negative value) before printing a label. Unit of measurement is defined in the Unit of Measure parameter. Range is -9999 to +9999.	0
Stop Adjust	Sets the length of media the printer feeds (positive value) or retracts (negative value) after printing a label. Unit of measurement is defined in the Unit of Measure parameter. Range is -9999 to +9999.	0
Media Calibration Mode	Selects the mode the printer uses to calibrate media. Use Slow if the printer has trouble identifying gaps or marks in media.	Fast

Media Settings (Continued)

Setting	Description	Default
Length (Slow Mode)	If Media Calibration Mode is set to Slow, the printer prints the media length plus 10 mm. This value sets an additional amount of media to be printed. Unit of measurement is defined in the Unit of Measurement parameter. Range is 0 to 3200.	0
LTS Sensitivity Level	Sets the sensitivity of the label taken sensor. Range is 0 to 14. Supported when the Cutter or Label Dispenser accessories are installed.	0
Power Up Action	Sets the action when you turn the printer on: <ul style="list-style-type: none"> • No Action • Formfeed - The printer feeds one label. • Testfeed - The printer prints a configuration label. 	No Action
Head Down Action	Sets the action when you close the print mechanism after opening it: <ul style="list-style-type: none"> • No Action • Formfeed - The printer feeds one label. • Testfeed - The printer prints a configuration label. 	No Action

Print Quality Settings

This section describes print quality settings. To view these settings:

- From the printer Main Menu, select **Settings > Printing > Print Quality**.
- From the printer web page, click the **Configure** tab, **Printing > Print Quality**.

Print Quality Settings

Setting	Description	Default
Print Speed	Sets how fast the printer prints labels. The unit of measure is defined in the Unit of Measure parameter.	100
Media Sensitivity	Sets the level of sensitivity of the media to the printhead heat for media and ribbon.	Variable
Darkness	Sets the image darkness for media and ribbon. Adjust this parameter with the Media Sensitivity parameter. Range is 1 to 100.	Variable
Contrast	Adjusts the blackness of the printing on the label in 2% increments from -10% to +10%.	+0%

Serial Port Settings

This section describes the serial port settings. To view these settings:

- From the printer Main Menu, select **Settings > Communications > Serial > COM1**.
- From the printer web page, click the **Configure** tab, **Communications > Serial**.



Note: These settings are not accessible unless the printer has a serial connection to a PC.

Serial Port Settings

Setting	Description	Default
Baud Rate	Transmission speed in bits per second (bps) for the serial port.	115200
Data Bits	Number of bits that define a character or byte.	8
Parity	Specifies how the printer checks the integrity of the transmitted data.	None
Stop Bits	Number of bits sent at the end of every character to allow the receiving signal hardware to detect the end of a character and to resynchronize with the character stream.	1
Hardware	Specifies if hardware flow control (RTS/CTS) is used to manage the rate of data transmission between the device and the host.	Disable
ENQ/ACK	Specifies if software flow control (ENQ/ACK) is used to manage the rate of data transmission between the device and the host.	Disable
XON/XOFF To	Specifies if software flow control (XON/XOFF) is used to manage the rate of data transmission to the host.	Disable
XON/XOFF From	Specifies if software flow control (XON/XOFF) is used to manage the rate of data transmission from the host.	Disable

Serial Port Settings (Continued)

Setting	Description	Default
New Line Character	Defines the characters that the printer echoes to the host to indicate that it has moved to a new line.	CR/LF

System I/O Settings

This section describes system I/O settings for the printer. To view these settings:

- From the printer Main Menu, select **Settings > System Settings > Manage I/O**.
- From the printer web page, click the **Configure** tab, **System Settings > Manage I/O**.

System I/O Settings

Setting	Description	Default
Wireless 802.11	Determines if the printer is allowed to communicate using its 802.11 radio. Supported only if the optional Wi-Fi+Bluetooth module is installed.	Enable
Bluetooth	Determines if the printer is allowed to communicate using its Bluetooth radio. Supported only if the optional Wi-Fi+Bluetooth module is installed.	Enable
RFID	Determines if the printer is allowed to communicate using its RFID radio. Supported only if the RFID module is installed.	Enable
Virtual COM	Determines if you can enable the USB port to be used as a virtual serial port. When you change this setting, you must restart the printer to enable the new setting.	Disable

System Network Services

This section lists the network services you can manage from the printer. You will only see **Manage Services** from the menus if you have an Ethernet or Wireless module installed in the printer. To view these services:

- From the printer Main Menu, select **Settings > System Settings > Manage Services**.
- From the printer web page, click the **Configure** tab, **System Settings > Manage Services**.

System Network Services

Service	Description	Default
Web Server	Determines if the web server is enabled in the printer.	Enable
FTP	Determines if the printer can use File Transfer Protocol (FTP).	Enable
Avalanche	Determines if the printer can be managed by Wavelink Avalanche.	Enable
Net1	Determines if the printer can use Telnet to communicate with Fingerprint.	Enable
SmartSystems	Determines if the printer can be managed by Intermec SmartSystems Foundation.	Enable
SNMP	Determines if the printer can use SNMP.	Enable
LPR	Determines if the printer can use the line printer server (LPR) daemon.	Enable
IKEv2	Determines if the printer can use IKEv2.	Disable
SSH	Determines if the printer can use Secure Socket Handling (SSH).	Enable
Telnet	Determines if the printer can use Telnet.	Enable
XML	Determines if the printer can use XML printing.	Enable

System Maintenance Alert Settings

This section describes the system maintenance alert settings, such as the odometer distance. To view these settings:

- From the printer Main Menu, select **Settings > System Settings > Maintenance Alerts**.
- From the printer web page, click the **Configure** tab, **System Settings > Maintenance Alerts**.

System Maintenance Alert Settings

Setting	Description	Default
Odometer (User Resettable)	Sets the length of media (in meters) that the printer prints before the Odometer (User Resettable) alert is sent, if this alert is configured. Unit of measurement is defined in the Unit of Measure parameter. Range is 0 to 4294967295.	0
Odometer (Printer)	Sets the length of media (in meters) that the printer prints before the Odometer (Printer) alert is sent. Unit of measurement is defined in the Unit of Measure parameter. Range is 0 to 4294967295.	0
Replace Printhead	Sets the length of media (in meters) that the printer prints before the Replace Printhead alert is sent, if this alert is configured. Unit of measurement is defined in the Unit of Measure parameter. Range is 0 to 4294967295.	0
Clean Printhead	Sets the length of media (in meters) that the printer prints before the Clean Printhead alert is sent, if this alert is configured. Unit of measurement is defined in the Unit of Measure parameter. Range is 0 to 4294967295.	0
Faulty Dot	Sets the number of faulty dots on the printhead before the Faulty Dot alert is sent, if this alert is configured. Range is 0 to 4294967295.	0

Wireless 802.11 General Settings

This section describes the 802.11 general settings. To view these settings:

- From the printer Main Menu, select **Settings > Communications > Wireless 802.11 > General**.
- From the printer web page, click the **Configure** tab, **Communications > Wireless 802.11**.

Wireless 802.11 General Settings

Setting	Description	Default
Network Name (SSID)	Defines the wireless network. To communicate, all access points and wireless devices must have the same network name, which is case-sensitive.	INTERMEC
Network Type	Selects the radio behavior of the printer. Ad Hoc mode allows the printer to communicate directly with another printer. Infrastructure mode allows the printer to communicate through an access point.	Infrastructure
Roaming	Controls the roaming inclination of the printer. The higher the level, the less inclined the printer is to switch access points based on the printer received signal strength (RSSI).	Off
Power Mode	Select the power management setting for the radio. Constant Awake provides the highest throughput but draws the most power. Power Saving conserves the most power but provides the lowest throughput. Fast Power Saving turns off components when they are not being used to draw less current.	Constant Awake
Channel	Sets the common channel that radios in Ad Hoc mode use to transfer data. Range is 1 to 13 (1 to 11 for FCC only).	1
Hidden SSID	Determines if the radio is allowed to look for SSIDs that have been hidden to prevent unauthorized devices from connecting to the wireless network.	Disable

Wireless 802.11 Network Settings

This section describes the 802.11 IPv4 and IPv6 settings. To view these settings:

- From the printer Main Menu, select **Settings > Communications > Wireless 802.11 > Network > IPv4 or IPv6**.
- From the printer web page, click the **Configure** tab, **Communications > Wireless 802.11**.

Wireless 802.11 Network Settings

Setting	Description	Default
(IPv4) IP Assignment Method	Sets how the printer obtains an IP address (for IPv4 networks).	DHCP
(IPv4) IP Address	Sets the unique network-level address that is assigned to each device in an IPv4 network.	0.0.0.0
Subnet Mask	Sets a number that defines the range of IP addresses that can be used in an IPv4 network.	0.0.0.0
Default Router	Sets the IP address of a router that is used when a device sends a packet to another subnet or to an unknown destination.	0.0.0.0
DHCP Response	Sets if the printer receives DHCP responses by broadcast or unicast.	Broadcast
(IPv6) IP Assignment Method	Sets how the printer obtains an IP address (for IPv6 networks).	Automatic
(IPv6) IP Address	Sets the unique network-level address that is assigned to each device in an IPv6 network.	Automatic

Wireless 802.11 Security Settings

This section describes the 802.11 security settings. To view these settings:

- From the printer Main Menu, select **Settings > Communications > Wireless 802.11 > Security**.
- From the printer web page, click the **Configure** tab > **Communications > Wireless 802.11**.

Wireless 802.11 Security Settings

Setting	Description	Default
Security Type	Selects the protocol the radio uses to verify its identity and makes sure that it is authorized to communicate on the wireless network.	None
Association	Selects the security method that the radio uses to get access to the wireless network.	Open/WEP
Pre-Shared Key	Defines the passphrase that allows the radio to authenticate over the wireless network (for both WPA and WPA2 security). Range is 8 to 64 characters.	None
Network Key Index	Selects the active network key to use for WEP security. Range is 1 to 4.	1
Network Key 1, Network Key 2, Network Key 3, Network Key 4	Defines a network key that is used for WEP security. Keys are entered in ASCII or hexadecimal (preceded by 0x) format.	Empty string
User Name	Sets the name that the printer uses when logging in to the network. Range is 1 to 96 characters.	None
Password	Sets the password that the printer uses when logging in to the network. Range is 1 to 96 characters.	None
Anonymous Name	Sets the outer EAP user name that the printer uses for logging in to the network. Maximum length is 96 characters.	Empty string

Wireless 802.11 Security Settings (Continued)

Setting	Description	Default
Inner Authentication	Selects the authentication method that is used when the EAP type is EAP-FAST, PEAP, or TTLS.	MSCHAPv2
CA Certificate	Sets the name of the Certificate Authority (CA) that verifies the server certificate. This CA should be the same one that was used to sign the server certificate.	intermec.pem
Client Certificate	Sets the name of the client certificate the printer uses to authenticate to the network using EAP-TLS. Maximum length is 128 characters.	None
Client Key	Sets the private key the printer uses for EAP-TLS. Maximum length is 128 characters. Use the certinstall.sh script to install the certificate correctly.	None
Server Common Name 1	Sets the certificate name that is on the primary authentication server. If this value is none, then the value for Server Common Name 2 is used. Range is 1 to 96 characters.	None
Server Common Name 2	Sets the certificate name that is on the secondary authentication server. If this value is none, then the value for Server Common Name 1 is used. Range is 1 to 96 characters.	None
Validate Certificate	Determines if the identity of the authentication server is verified using its certificate when using EAP-TTLS, PEAP, or EAP-TLS. Intermec recommends that you set Validate Certificate to Yes .	No
PAC	Sets the name of the Protected Access Credential (PAC) that is used for EAP-FAST authentication. The printer uses this file if Acquire PAC is on and the current installed PAC fails to authenticate the printer to the network.	eap-fast.pac

Wireless 802.11 Security Settings (Continued)

Setting	Description	Default
Acquire PAC	Determines if automatic PAC file provisioning is on for EAP-FAST authentication.	On
Fast Roaming (CCKM)	Determines if the printer can roam from one access point to another without reauthenticating with the server. CCKM only works in wireless networks using LEAP.	Disable

C

Print Labels with INPrint

This section explains how to use the INPrint feature to print labels.

About the INPrint Page

The INPrint page features sample web forms you can use to quickly and easily print single labels if you are using the Fingerprint or Direct Protocol language on your printer. You select a web form from the lists and enter information in the fields for that label. You can then preview and print the label.

The printer firmware includes several predefined label formats. You can also copy your own label formats to the printer and print them from this page.



Print INPrint Labels

If the printer is connected to an Ethernet or Wi-Fi network, you can print labels by entering information in a web form. You access web forms through the printer web page.

- 1 On your desktop PC, start a browser.
- 2 In the **Location** or **Address** bar, type the printer IP address and press **Enter**. The printer web page appears.
- 3 Click the **INPrint** tab.

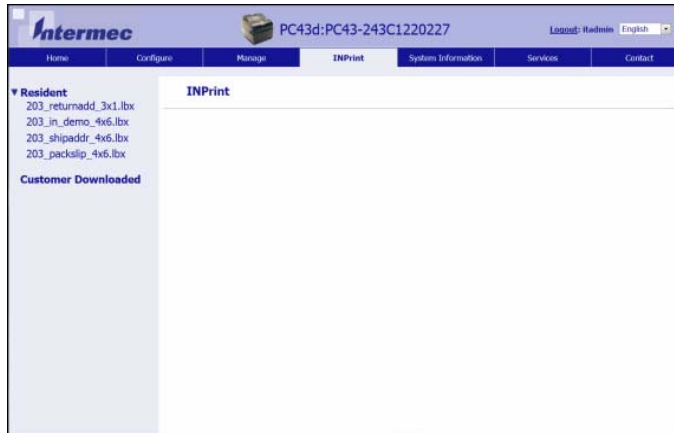

- 4 Select the web form you want to print:
 - If you created the web form yourself, click **Customer Downloaded** and then select the web form in the list.
 - To use one of the Resident (Intermec-supplied) web forms, click **Resident** and then select the web form in the list.



- 5 Type information in the web form as needed.
- 6 (Optional) To preview the label on screen, click **Preview**.
- 7 To print the label, click **Print**.

Predefined INPrint Label Formats

Predefined INPrint Label Formats and Sample Illustrations

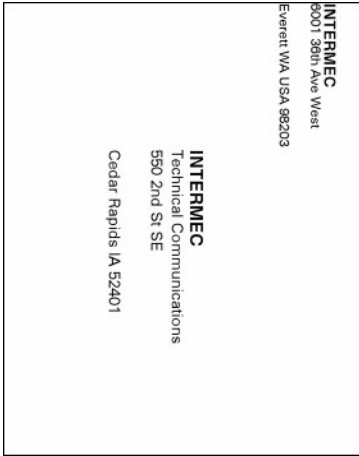
Format Name	Sample
203_returnadd_3x1.lbx	 <p>INTERMEC 6001 38th Ave W Everett WA USA 98203</p>
203_demo_4x6.lbx	 <p>INTERMEC PRINTERS</p> <p>INTERMEC TECHNOLOGIES 6001 38th Ave W Everett WA USA 98203</p> <p>CODE 39 363 15 561</p> <p>POCKET FIELD</p> <p>EXPANDED</p>
203_shipaddr_4x6.lbx	 <p>INTERMEC 6001 38th Ave West Everett WA USA 98203</p> <p>INTERMEC Technical Communications 550 2nd St SE Cedar Rapids IA 52401</p>

**Predefined INPrint Label Formats and Sample Illustrations
(Continued)**

Format Name	Sample										
203_packslip_4x6.lbx	<table border="1"><tr><td>INTERMEC 6001 36th Ave W Everett WA USA 98203 ORDER NO: 1000 Item No. Description</td><td>PACKING SLIP Phone: 425-348-2600 SHIP DATE: 1-Feb-2012 Order Qty Pick Qty</td></tr><tr><td>PC23d</td><td>100 100</td></tr><tr><td>PC43d</td><td>250 250</td></tr><tr><td>PC43t</td><td>500 500</td></tr><tr><td colspan="2">TOTALS:</td></tr></table>	INTERMEC 6001 36th Ave W Everett WA USA 98203 ORDER NO: 1000 Item No. Description	PACKING SLIP Phone: 425-348-2600 SHIP DATE: 1-Feb-2012 Order Qty Pick Qty	PC23d	100 100	PC43d	250 250	PC43t	500 500	TOTALS:	
INTERMEC 6001 36th Ave W Everett WA USA 98203 ORDER NO: 1000 Item No. Description	PACKING SLIP Phone: 425-348-2600 SHIP DATE: 1-Feb-2012 Order Qty Pick Qty										
PC23d	100 100										
PC43d	250 250										
PC43t	500 500										
TOTALS:											

Linux Copyright Information

This software is provided in pertinent parts by the following copyright holders:

Copyright or License Text	Link to Source Code
BlueZ - Bluetooth protocol stack for Linux	http://www.bluez.org
LPRng, IFHP, and LPRng Tool License	http://www.lprng.com
psplash - a lightweight framebuffer splashscreen for embedded devices	http://git.yoctoproject.org/cgit/cgit.cgi/psplash
udhcp DHCP client	http://busybox.net/products.html
Copyright © 1997 Warren W. Gay VE3WWG	http://sourceforge.net/projects/wavplay/
EINA-EFL data type library, Copyright © 2008 Cedric Bail	http://www.enlightenment.org
Copyright © 2008 Christian Kellner, Samuel Cormier-Iijima	http://www.gtk.org
Copyright © 2001, 2002 Brian Stafford <brian@stafford.uk.linux.net>	http://www.stafford.uklinux.net/libesntp/
Copyright © 1996 Markus Franz Xaver, Johannes Oberhumer	http://www.oberhumer.com/opensource/lzo/
Copyright © 2002 Nicolas Pitre Copyright © 2003 Texas Instruments, Inc. Copyright © 2003 Chris Larson. Copyright © 2004 Michael Opdenacker <michaelo@handhelds.org> Original version: Copyright © 2001 Russell King.	http://tslib.berlios.de/
Mono compilers and tools. Copyright © 2001, 2002, 2003, Ximian and contributors.	http://www.mono-project.com/Main_Page
Copyright (C) 2003 WIDE Project.	https://fedorahosted.org/dhcpv6/
Copyright (c) 2002-2008 Matt Johnston Portions copyright (c) 2004 Mihnea Stoenescu	https://matt.ucc.asn.au/dropbear/dropbear.html
Copyright (c) 2004, Jan Kneschke, incremental	http://www.lighttpd.org/
Copyright (C) 1994-2008 Lua.org, PUC- Rio.	http://www.lua.org/

Copyright or License Text	Link to Source Code
Copyright (C) 2004, 2005 WIDE Project.	http://www.racoon2.wide.ad.jp/w/
Copyright (C) 1995, 1996, 1997, 1998, and 1999 WIDE Project.	http://ipsec-tools.sourceforge.net/
Copyright 1989, 1991, 1992 by Carnegie Mellon University Derivative Work - 1996, 1998-2000 Copyright 1996, 1998-2000 The Regents of the University of California Copyright (c) 2001-2003, Networks Associates Technology, Inc Portions of this code are copyright (c) 2001-2003, Cambridge Broadband Ltd. Copyright © 2003 Sun Microsystems, Inc., 4150 Network Circle, Santa Clara, California 95054, U.S.A. Copyright (c) 2003-2010, Sparta, Inc	http://www.net-snmp.org/
Copyright (C) 2000-2011 Carsten Haitzler and various contributors Copyright (c) 1999 - Carsten Haitzler (The Rasterman)	http://www.enlightenment.org/
Copyright (c) 2001, 2002, 2003, 2004, 2005, 2006 Expat maintainers.	http://www.libexpat.org/
Copyright 2009 Intermec Technologies Corp. All rights reserved. Based on code from Frank Da Cruz's excellent book, <i>_Kermit: A File Transfer Protocol_</i> , Digital Press, 1986.	http://www.columbia.edu/kermit/
Copyright (c) 1997 Eric S. Raymond	http://giflib.sourceforge.net/
Copyright (C) 1991-1998, Thomas G. Lane.	http://www.ijg.org/
Copyright 2006 Richard Wilson <richard.wilson@netsurf-browser.org> Copyright 2008 Sean Fox <dyntryx@gmail.com>	http://www.netsurf-browser.org/projects/libnsbmp/
Copyright (c) 1998-2009 Glenn Randers-Pehrson	http://www.libpng.org/pub/png/libpng.html

Copyright or License Text	Link to Source Code
Copyright (c) 1998-2007 The OpenSSL Project.	http://www.openssl.org/
(C) 1995-2004 Jean-loup Gailly and Mark Adler	http://zlib.net/
Copyright (c) 2003-2009, Jouni Malinen <j@w1.fi> and contributors	

This software is provided by all copyright holders “as is” and any express or implied warranties, including, but not limited to, the implied warranties of merchantability and fitness for a particular purpose are disclaimed. In no event shall any copyright holder or contributors be liable for any direct, indirect, incidental, special, exemplary, or consequential damages (including, but not limited to, procurement of substitute goods or services; loss of use, data, or profits; or business interruption) however caused and on any theory of liability, whether in contract, strict liability, or tort (including negligence or otherwise) arising in any way out of the use of this software, even if advised of the possibility of such damage.



by Honeywell

6001 36th Avenue West
Everett, Washington 98203
U.S.A.

tel 425.348.2600

fax 425.355.9551

www.intermec.com

© 2014 Intermec by Honeywell
All rights reserved.

PC23 and PC43 Desktop Printer User Manual



P/N 935-044-005